

Proteus-IV User Manual

TABLE OF CONTENTS

GENERAL OVERVIEW	4
COMMUNICATION	4
COM PORTS	4
COM PORTS: PINOUTS	4
COM PORTS: BAUD RATE	5
COM PORTS: DEVICE TYPES	5
COM PORTS: CONFIGURATION	5
CSV FORMATS	6
INTERFACE TO PC	6
INTERFACE TO GPS MODEM	6
VIDEO INPUT & OUTPUT	7
VIDEO FRAME RATES	8
VIDEO DELAY	8
IRIG INPUT	8
SOFTWARE WIZARDS	9
INSERT TEXT	9
INSERT GRAPHICS	11
INSERT VARIABLES FROM CSV SENTENCE	13
INSERT DATA FROM RS232 COMMAND	13
INSERT GPS DATA	16
INSERT NMEA DATA	18
INSERT TIME, DATE (IRIG, GPS, RTC, ATC)	18
INSERT AEROSPACE DATA	19
INSERT ANALOG DATA	20
INSERT QUADRATURE DATA	22
INSERT AIRCRAFT SITUATION AWARENESS	25
INSERT ROV SITUATION AWARENESS	27
INSERT RETICLE	29
INSERT VIDEO MARKER	31
INSERT COUNT UP TIMER	34
INSERT PROGRESS BARS & SLIDERS	35
WRITE GEOTAG DATA	37
READ GEOTAG DATA	37
PROTEUS COMMANDS	40
TRANSMIT A COMMAND SCRIPT	40
PROTEUS REGISTERS	41

SPECIFICATIONS	48
MAXIMUM INPUT VOLTAGE	48
INPUT CONNECTOR	48
MAXIMUM TEMPERATURE.....	48
WEIGHT & DIMENSION	48
FRONT PANEL LED	48
PCB DIMENSION	49
APPENDIX A - KEYBOARD	50
PS2 KEYBOARD COMMANDS.....	50
KEYBOARD SHORT CUT	50
APPENDIX B – DOWNLOAD CUSTOM FONTS.....	51
DOWNLOAD USER FONTS	51
APPENDIX C – INSTALL MEMTOOL.....	52
INSTALL MEMTOOL.....	52
CONFIGURE MEMTOOL	53
APPENDIX D – DOWNLOAD CPU FIRMWARE	54
FIRMWARE UPGRADE.....	54
APPENDIX F – DOWNLOAD FPGA FIRMWARE	56
FPGA UPGRADE	56
APPENDIX G – ANALOG INPUT SENSOR CALIBRATION	57
EXAMPLE 1	57
EXAMPLE 2.....	58
EXAMPLE 3.....	59
EXAMPLE 4.....	61
EXAMPLE 5.....	62
APPENDIX H – WIFI SETTING	63
WIFI	63
APPENDIX I – TERMINAL BLOCKS.....	64
HOW TO INSERT WIRE INTO TERMINAL BLOCKS	64

GENERAL OVERVIEW

Video Overlay is a method by which computer-generated images are superimposed on video. Properly transformed images appear as if they are an integral part of the scene without impeding the video of the actual environment. Proteus provides professional, scientific and industrial users with the capability to overlay crisp and clear texts, graphics and telemetry generated information into an incoming HD & SD video in real time. Proteus accepts video in HD-SDI, HDMI, Y/C and Composite. It generally, does not need to be connected to a computer for normal operation.

COMMUNICATION

COM PORTS

Proteus provides 4 x serial ports (COM1 thru COM4) for communication with the external devices:

COM PORT	Alternative 1	Alternative 2	Alternative 3
COM1	RS232 (Rear Panel DB9)	-	-
COM2	RS232 (Internal TB: J45)	RS422 (Internal TB: J50, J61)	WiFi
COM3*	RS232 (Rear Panel USB)	RS232 (Internal TB: J46)	
COM4	RS232 (Internal TB: J52)	-	-

COM PORTS: PINOUTS

COM PORT	Connector	Modes	Isolated	Pin assignments
COM1	DB9	RS232	Yes	DB9: 2=RX, 3=TX, 5=GND
COM2	Internal	RS232 RS422	-	J45: 1=5V, 2=TX, 3=RX, 4=GND J50: 1=RX+, 2=RX-, 3=GND J61: 1=TX-, 2=TX+, 3=GND
COM3	USB	RS232	-	J46: 1=5V, 2=TX, 3=RX, 4=GND
COM4	Internal	RS232	Yes	J52: 1=5V, 2=TX, 3=RX, 4=GND

TB = Terminal Block

*COM3 is automatically routed from internal connector **J46** to the rear panel **USB port** when USB connection is established. Users who intend to develop code to interface to COM3(USB) must ensure their firmware can **assert RTS signal**.

COM PORTS: BAUD RATE

COM ports are configured for N, 8, 1 (No parity, 8 bits, 1 Stop) and can be set to the following baud rates:

- 4800, 9600, 19200, 38400, 57600, 115200, 921600 (COM3 only)

COM PORTS: DEVICE TYPES

COM ports can be interfaced to various sensors/devices. Table below shows the current list and their corresponding Device Type setting.

Attach Sensor/Device	Corresponding Device Type
CSV (Comma Separated Variable) ASCII Sentence	CSV1, CSV2, CSV3 (See CSV formats for more detail)
All NMEA-0183 compatible devices i.e. GPS Modem, Sounder, etc.	CSV1
ProteusApp	CSV1
PuTTY or similar program	CSV1
Vector NAV IMU	VectorNav
General Dynamic CINEFLEX	CINEFLEX
Smart Micro Radar	ALTIMETER
APOS for HIPAP system (KONGSBERG)	SIMRAD

COM PORTS: CONFIGURATION

Press F9 to display the Main Menu. Follow Figure 1:Figure 2 to configure COM ports for desire baudrate & device type

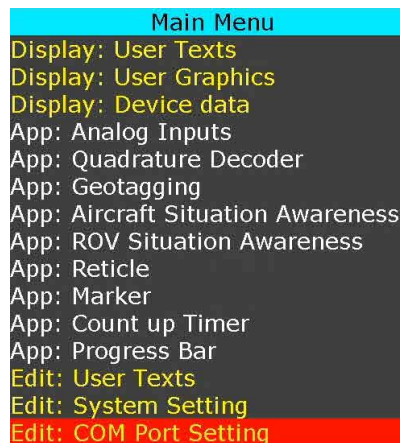

Figure 1

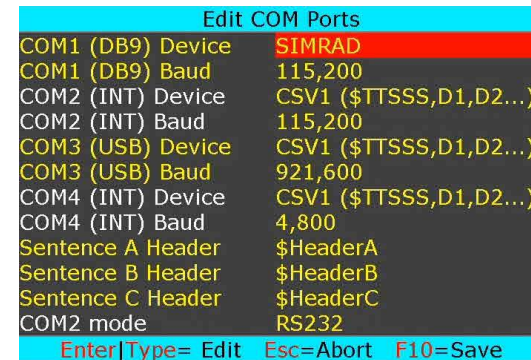

Figure 2

CSV FORMATS

Many sensors transmit ASCII sentence also known as Comma Separated Variables (CSV). Proteus supports 3 different ASCII sentences:

CSV Format	Sentence Structure	Example
CSV1	\$TTSSS , VAR1, VAR2, VAR3, <CR><LF>	\$MYHEADER , 45, 315, 200, 100<CR><LF>
CSV2	\$VAR1 , VAR2, VAR3, <CR><LF>	\$45,315,200,100 <CR><LF>
CSV3	VAR1, VAR2, VAR3, <CR><LF>	45,315,200,100<CR><LF>

Follow Figure 1-2 to define \$TTSSS header

Upon reception of a **CSV** sentence and successful confirmation of the sentence header \$TTSSS (only CSV1), Proteus parses the sentence. Parsed variables (VAR1 ... VAR2) are sequentially stored in [Register](#) # {52-63}, {65-72}, {74-81}. Any widgets linked to these registers will automatically get updated.

INTERFACE TO PC

Options	Required Cable
Using USB in the rear panel	Standard USB Cable. User must install memtool. See Appendix D for more detail.
Using DB9 in the rear panel	NULL modem cable

INTERFACE TO GPS MODEM

COM1 (DB9) is configured as DTE (PC) i.e. RX=Pin2, TX=Pin3. Thus, sensors such as GPS can be directly connected to the DB9 without the need for NULL modem cable.

VIDEO INPUT & OUTPUT



Proteus provides the following video input & output:

- SDI (HD & SD)
- HDMI (HD & SD)
- Y/C
- Composite

Proteus does *not support* HDMI video with *HDCP*. It can only process one video input at a given time. If more than one input is connected at the same time, Proteus selects a video input based on the following priorities:

1. SDI
2. HDMI
3. Y/C
4. Composite

Proteus does not scale video and the output resolution follows the input. Proteus provides simultaneous video outputs as shown below:

Video Input	Simultaneous Video Outputs			
HD-SDI (HD Video)	HD-SDI	HDMI (HD)		
HD-SDI (SD Video)	HD-SDI	HDMI (SD)	Y/C	Composite
HDMI (HD Video)	HD-SDI	HDMI (HD)		
HDMI* (SD Video)	SD-SDI	HDMI* (SD)	Y/C	Composite
Y/C	SD-SDI	HDMI* (SD)	Y/C	Composite
Composite	SD-SDI	HDMI* (SD)	Y/C	Composite

VIDEO FRAME RATES

Proteus is compatible with the following video formats:

NTSC 480i @ 60 Hz
PAL 576i @ 50 Hz
720p @ 50 / 59.94 / 60 Hz
1080i @ 50 / 60 Hz
1080p @ 23.98 / 24 / 25 / 29.97 / 30 Hz
1080PsF @ 23.98 / 24 Hz

VIDEO DELAY

All OSD functions are superimposed into the video "on-the-fly." As a result, there is no degradation in video quality and the delay from the video input to the video output is < 290 nsec.

IRIG INPUT

Composite input can be used to input an external unmodulated IRIG-B signal. Proteus can decode IRIG-B time & date code.

Composite input can be also used to input an external PPS signal. PPS signal can be used to support a very accurate count up/down timer.

SOFTWARE WIZARDS

INSERT TEXT

Up to 96 user texts can be stored in FLASH memory.

Press F9 to display Main Menu. Follow Figure 3:Figure 4 to enter/edit user texts.

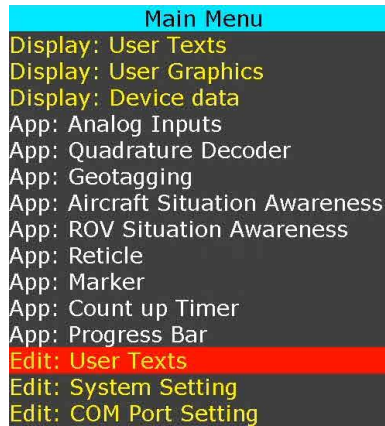

Figure 3

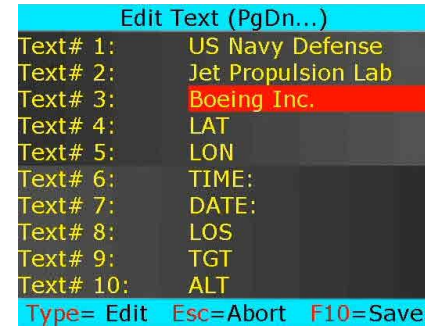

Figure 4

Follow Figure 5:Figure 6 to insert and/or format text.



Figure 5

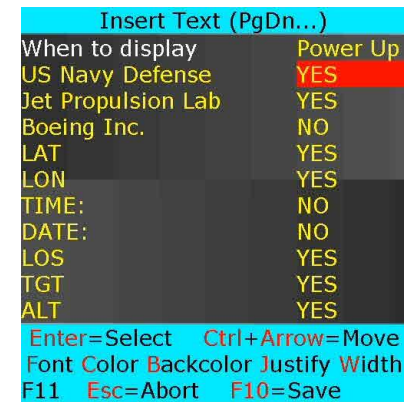

Figure 6

Use [shortcuts](#) to change text attributes: **F**ont select, text **C**olor, **↕↔** text position, text **B**ackground, field **W**idth and text **J**ustification. “**When to display**” allows user to select when text is displayed. Options are: at power up or when function key F1..F7 is pressed.

Once complete, text overlay should appear as shown in Figure 7.

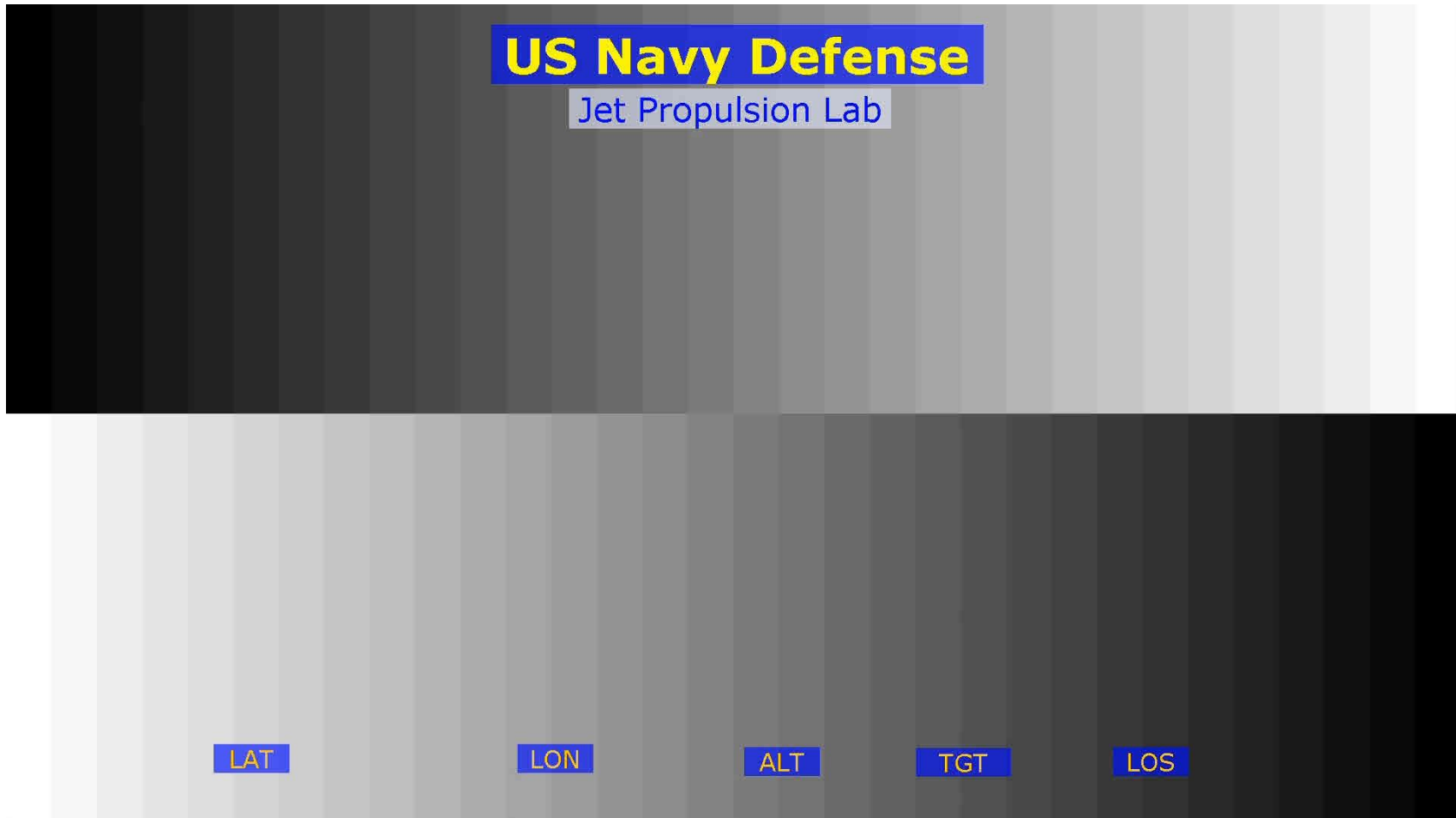

Figure 7

INSERT GRAPHICS

Up to 96 PNG (Indexed Color, 8Bits/Channel) & PCX images can be stored in the FLASH memory. Use Proteus App to load images into FLASH memory. For the interim time, number of pixels in the PNG image should be less than 65535. i.e. H=256 x W=256, or H=100 x W=640 etc. Future firmware release will increase image size.

Press F9 to display Main Menu. Follow Figure 8:Figure 9 to insert images.

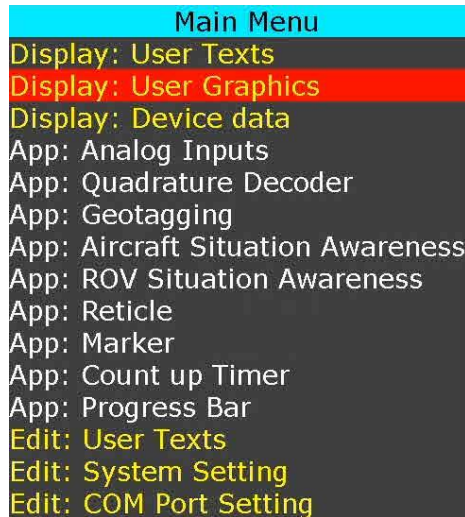

Figure 8



Figure 9

While in Figure 9, use \updownarrow to select a desire image and use $\text{Ctrl} + \updownarrow \leftrightarrow$ to position the image on screen.

"When to display" allows user to select when image is displayed. Options are: At power up or when function key F1..F7 is pressed.

Once complete, graphics images should appear as shown in Figure 10.

US Navy Defense

Jet Propulsion Lab



LAT

LON

ALT

TGT

LOS



Figure 10

INSERT VARIABLES FROM CSV SENTENCE INSERT DATA FROM RS232 COMMAND

Configuring a COM port as “**CSV***” allows Proteus to receive an ASCII sentence or any unique NMEA sentence. Upon reception of a sentence, Proteus parses the sentence. Parsed variables (tokens) are sequentially stored in Register # 52-63, 65-72, 74-81. Any widgets linked to these registers will automatically get updated.

CSV1 Example:

This sentence must start with a unique header that matches the user defined value. *Follow Figure 1-2 to define your unique header.*

```
$HeaderA,1,22,333,4444,55555,666666,7777777,88888888,99999999,1234,2345,3456*XX
```

Proteus can be configured to receive and parse up to 3 unique CSV sentences.

Follow Figure 1:Figure 2 to configure COM port for desire baudrate and define CSV headers

Follow Figure 11:Figure 15 to insert CSV parameters. Once in Figure 13, use PgDn to browse through CSV sentence A, B, C tokens.

Alternatively, launch *ProteusApp USB*, select *Demo/Tutorial* tab and write configuration file *C:\VideoLogix-IV\config\ConfigCsv* to restore screen as shown in Figure 16



Figure 11



Figure 12

Tokens (PgDn...)	
When to display	Power Up
Token A1	NO
Token A2	YES
Token A3	YES
Token A4	YES
Token A5	YES
Token A6	YES
Token A7	YES
Token A8	YES
Token A9	YES
Token A10	NO
Token A11	NO
Token A12	NO

Enter=Select Ctrl+Arrow=Move
 Font Color Backcolor Justify Width
 Esc=Abort F10=Save

Figure 13

Tokens (PgDn...)	
Token B1	YES
Token B2	YES
Token B3	YES
Token B4	YES
Token B5	NO
Token B6	NO
Token B7	NO
Token B8	NO

Enter=Select Ctrl+Arrow=Move
 Font Color Backcolor Justify Width
 F03 Esc=Abort F10=Save

Figure 14

Tokens (PgDn...)	
Token C1	YES
Token C2	YES
Token C3	YES
Token C4	YES
Token C5	NO
Token C6	NO
Token C7	NO
Token C8	NO

Enter=Select Ctrl+Arrow=Move
 Font Color Backcolor Justify Width
 F03 Esc=Abort F10=Save

Figure 15

Assuming tokens are selected as shown in Figure 13:Figure 15, their default value should appear as shown in Figure 16.

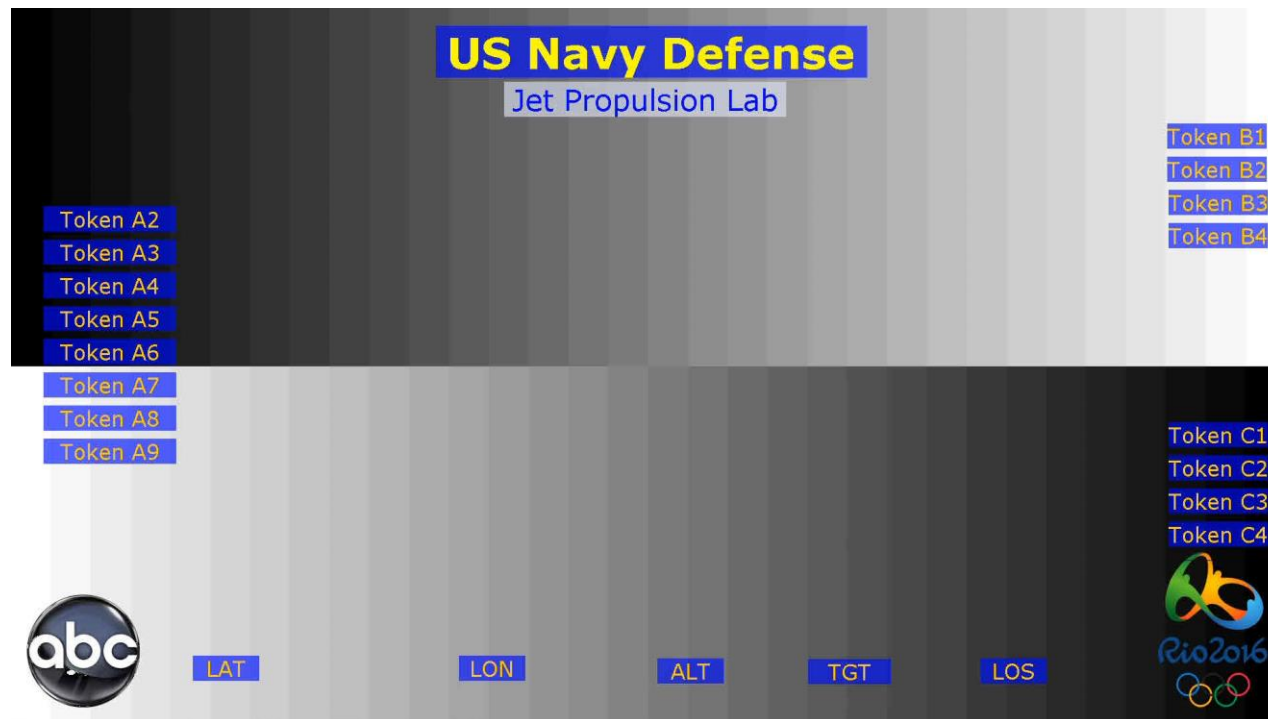

Figure 16

Upon transmission of the following sentences, the token values should appear as shown in Figure 17.

```
$HeaderA,1,22,333,4444,55555,666666,7777777,88888888,999999999*XX  
$HeaderB,AAA,BBBB,CCCCC,DDDDDD*XX  
$HeaderC,This,is,an,Example*XX
```

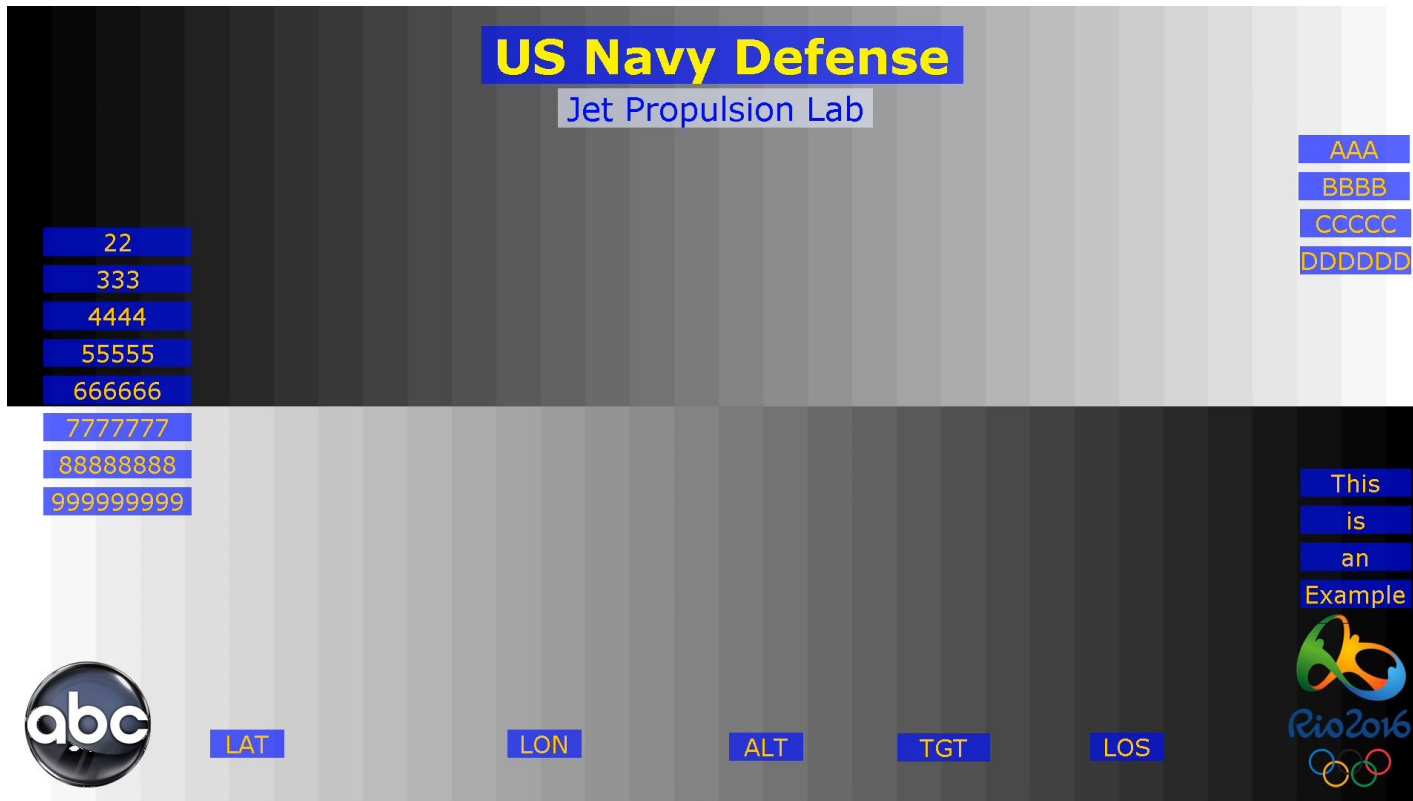

Figure 17

Follow steps below to send the above sentences to Proteus

1. Run *ProteusApp USB*
2. Select *Demo/Tutorial* tab.
3. Click Run Now button and select script *C:\VideoLogix-IV\script\2-CSV Sentences.txt*

Individual tokens can also be modified by sending command **\$VL43**. For example, to change tokenA2 and tokenA3 (register #53, #54) to 777, 888, transmit the following command: **\$VL43,53,777,888*XX**.

User can exercise command **\$VL43** by sending script *C:\VideoLogix-IV\script\3-Update Token.txt*

INSERT GPS DATA

GPS modem can be connected to COM1,2,3 ports.

Follow Figure 1:Figure 2 to configure COM port for desire baudrate

Follow Figure 18:Figure 20 to insert GPS parameters.



Figure 18



Figure 19



Figure 20

As soon as a modem is connected to the selected COM port, the latitude, longitude, time & data should appear as shown in Figure 21.

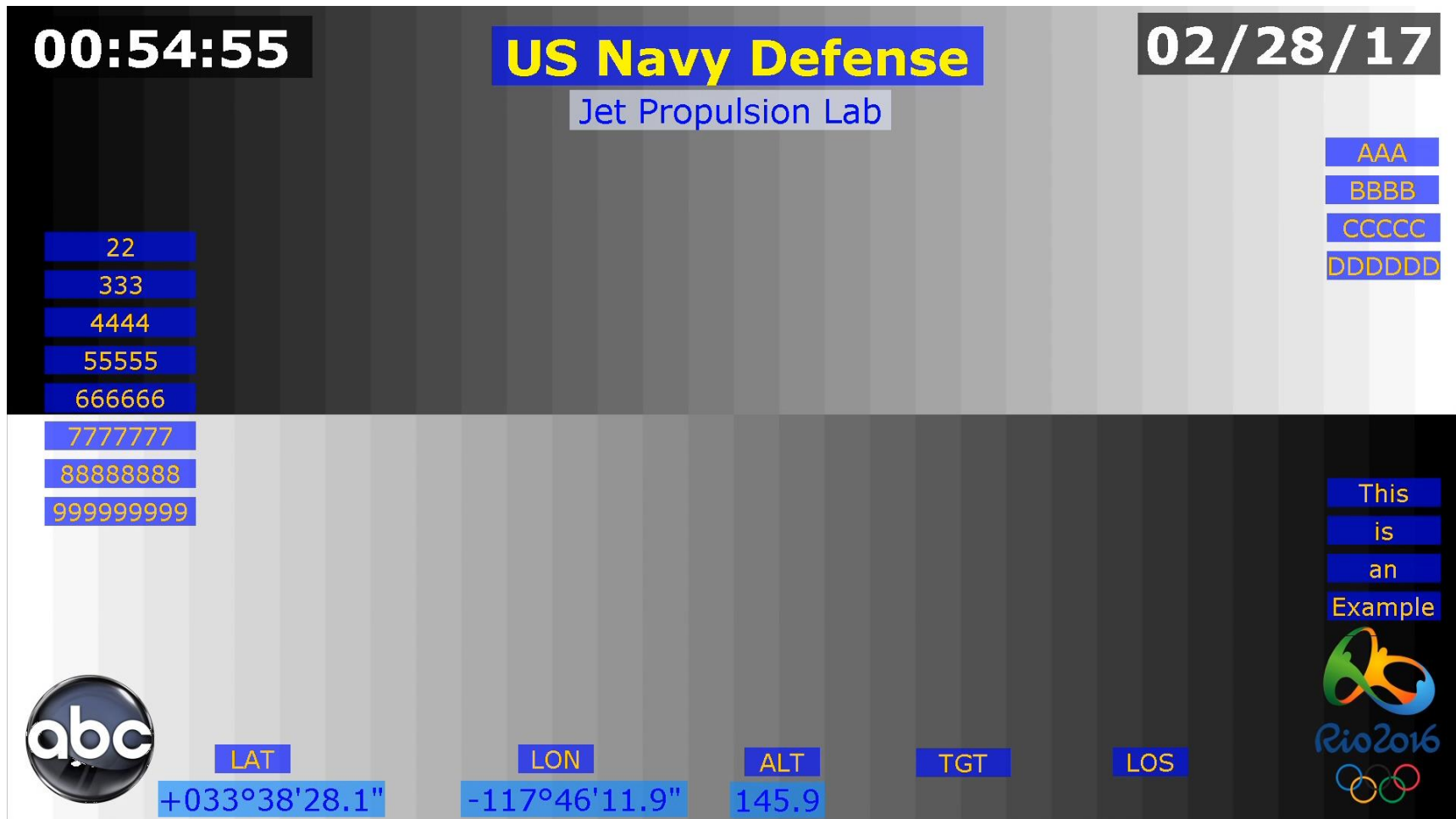

Figure 21

INSERT NMEA DATA

NMEA compliant sensors can be connected to COM1, 2, 4. Follow Figure 1:Figure 2 to configure the COM port for desire baudrate.

Follow Figure 22:Figure 24 to insert NMEA parameters.



Figure 22



Figure 23

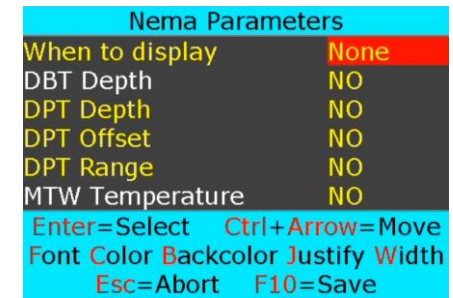

Figure 24

Proteus implicitly supports many NMEA sentences such as: \$GPRMC, \$GPGGA, \$GPWPL, \$GPGSA, \$GPGSV, \$SDDPT, \$SDDBT, \$WIMTW, \$VNINS, \$VNIMU, \$VNYPR, etc.

INSERT TIME, DATE (IRIG, GPS, RTC, ATC)

Follow Figure 25:Figure 27 to insert Proteus parameters.



Figure 25



Figure 26

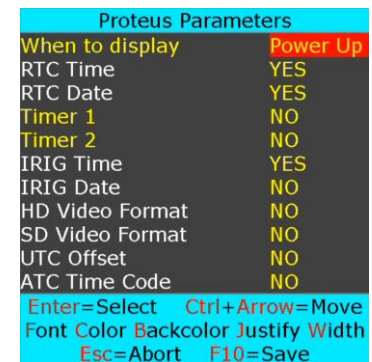

Figure 27

INSERT AEROSPACE DATA

Devices such as Vector NAV IMU, Boeing Cineflex, Smart micro Radar can be directly connected to COM 1, 2, 4 port.

Follow Figure 1:Figure 2 to configure the COM port for desire baud rate.

Follow Figure 28:Figure 31 to insert Vector NAV parameters over video. Once in Figure 30, press PgDn to browse through various devices.



Figure 28



Figure 29



Figure 30

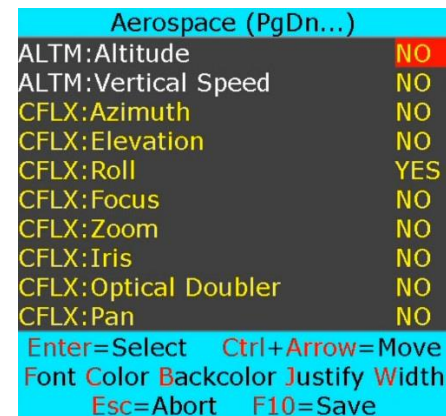

Figure 31

INSERT ANALOG DATA

Proteus provides 8 optically isolated analog inputs via [internal terminal block J58](#).

TB:J58	Description	Range	Alternative 1	Alternative 2
Pin 1	Analog Input 1	5V, 10V, ±2.5V, ±5V, ±10V	Single ended	Differential 1
Pin 2	Analog Input 2	5V, 10V, ±2.5V, ±5V, ±10V	Single ended	
Pin 3	Analog Input 3	5V, 10V, ±2.5V, ±5V, ±10V	Single ended	Differential 2
Pin 4	Analog Input 4	5V, 10V, ±2.5V, ±5V, ±10V	Single ended	
Pin 5	Analog Input 5	5V, 10V, ±2.5V, ±5V, ±10V	Single ended	Differential 3
Pin 6	Analog Input 6	5V, 10V, ±2.5V, ±5V, ±10V	Single ended	
Pin 7	Analog Input 7	5V, 10V, ±2.5V, ±5V, ±10V	Single ended	Differential 4
Pin 8	Analog Input 8	5V, 10V, ±2.5V, ±5V, ±10V	Single ended	

Input Range					Corresponding 12-bit ADC Count
5V	10V	±2.5V	±5V	±10V	
0	0	-2.5	-5	-10	0
2.5	5	0	0	0	2047
5	10	+2.5	+5	+10	4095

Result of each analog input is available in raw or map format. The relation between the raw and map data is shown below:

$$Map = m * raw + b$$

$$m = slope$$

$$b = intercept$$

Please review [Appendix-G](#) to learn how to compute slope & intercept for you desire sensor.

CONFIGURE ANALOG INPUTS

Follow Figure 32:Figure 34 to configure analog inputs.

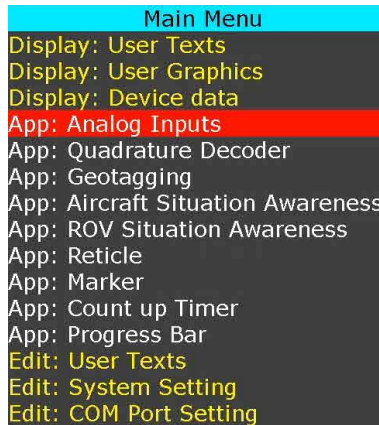

Figure 32

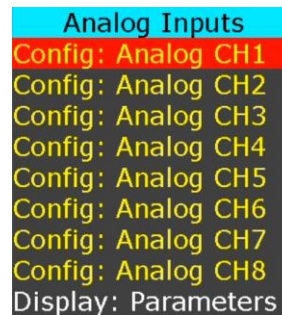

Figure 33

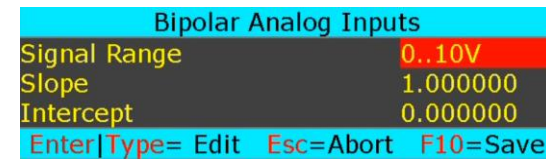

Figure 34

Follow Figure 32 & Figure 35:Figure 36 to insert analog input raw and map data.

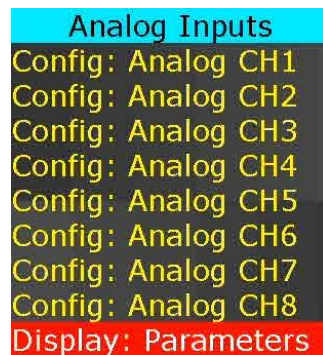

Figure 35

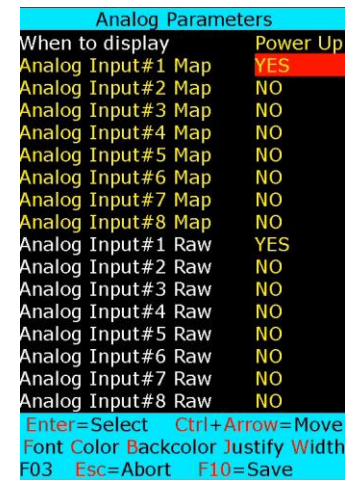

Figure 36

INSERT QUADRATURE DATA

Proteus provides 4 optically isolated Quadrature inputs via [internal terminal block J59](#).

Terminal Block (J59) Pins	Alternative 1	Alternative 2	Alternative 3
DIN1	Quadrature Counter 1		General purpose Input 1 (GPI1)
DIN2			General purpose Input 2 (GPI2)
DIN3	Quadrature Counter 2		General purpose Input 3 (GPI3)
DIN4			General purpose Input 4 (GPI4)
DIN5	Quadrature Counter 3		General purpose Input 5 (GPI5)
DIN6			General purpose Input 6 (GPI6)
DIN7	Quadrature Counter 4	INDEX for Counter 1	General purpose Input 7 (GPI7)
DIN8		INDEX for Counter 2	General purpose Input 8 (GPI8)

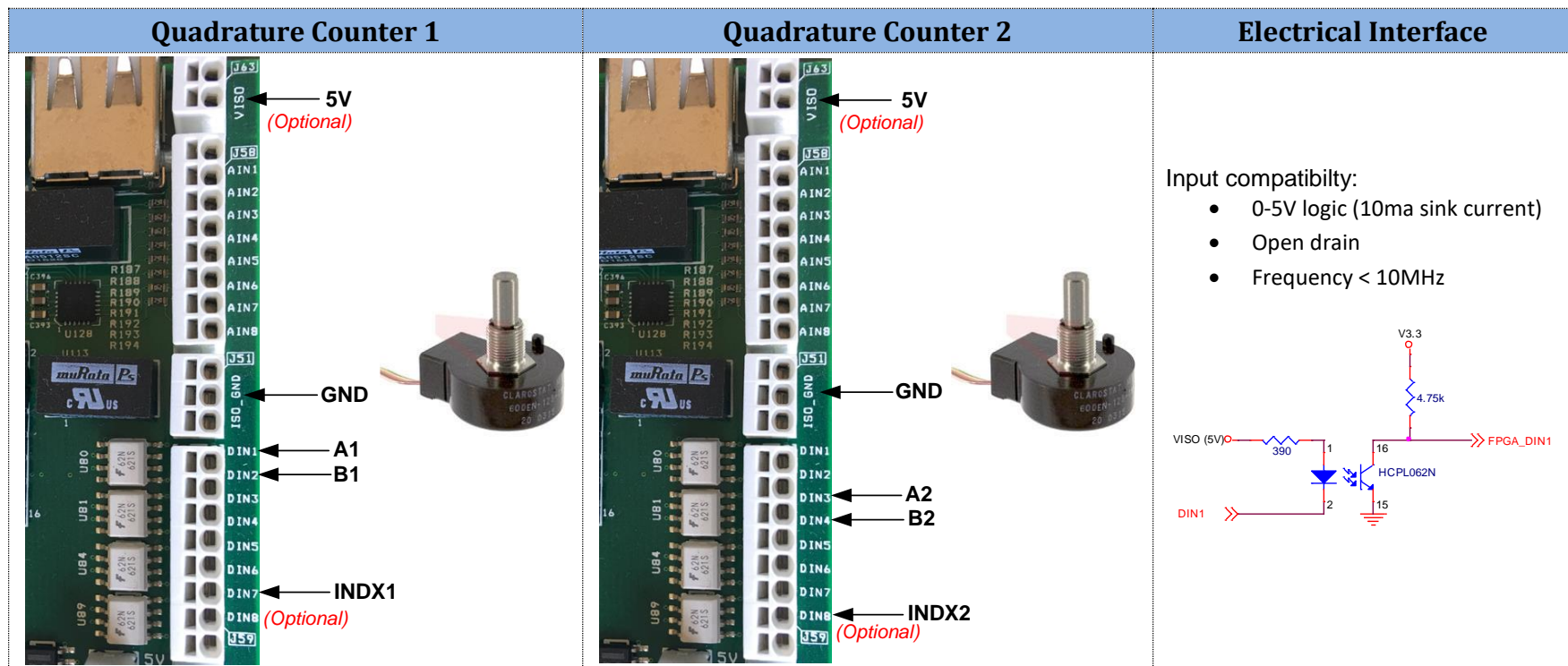

Picture below shows a typical wiring connection for Quadrature Counter #1 and #2



Please review [Appendix I – Terminal blocks](#) to learn how best insert wire into terminal blocks

CONFIGURE QUADRATURE INPUTS

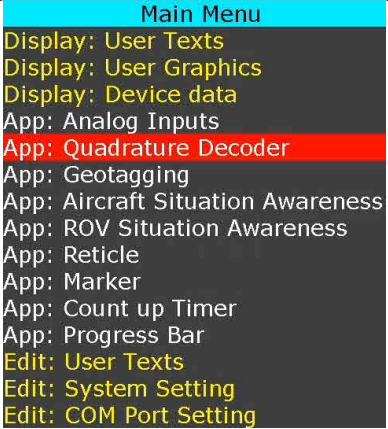
Follow Figure 37:Figure 39 to configure quadrature inputs for desire line resolution (x1, x2, x4) and count format (\pm Count or +Count).

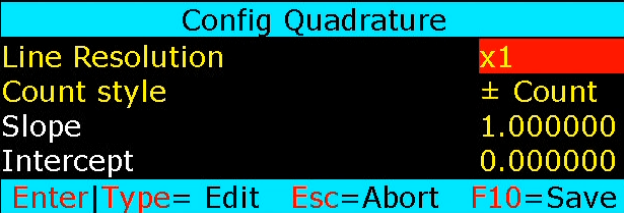
 <p>Main Menu Display: User Texts Display: User Graphics Display: Device data App: Analog Inputs App: Quadrature Decoder App: Geotagging App: Aircraft Situation Awareness App: ROV Situation Awareness App: Reticle App: Marker App: Count up Timer App: Progress Bar Edit: User Texts Edit: System Setting Edit: COM Port Setting</p> <p>Figure 37</p>	 <p>Quadrature Input Config: Quadrature 1 Config: Quadrature 2 Config: Quadrature 3 Config: Quadrature 4 Display: Parameters</p> <p>Figure 38</p>	 <p>Config Quadrature Line Resolution x1 Count style \pm Count Slope 1.000000 Intercept 0.000000 Enter Type= Edit Esc=Abort F10=Save</p> <p>Figure 39</p>
---	---	---

Follow Figure 37 & Figure 40:Figure 41 to display quadrature raw or map counts.

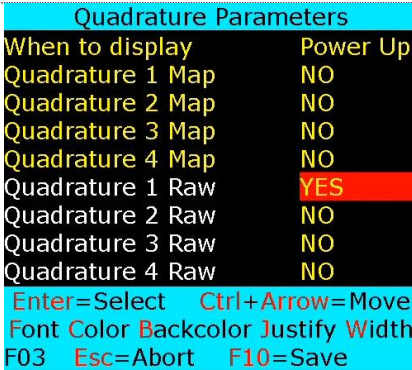
 <p>Quadrature Input Config: Quadrature 1 Config: Quadrature 2 Config: Quadrature 3 Config: Quadrature 4 Display: Parameters</p> <p>Figure 40</p>	 <p>Quadrature Parameters When to display Power Up Quadrature 1 Map NO Quadrature 2 Map NO Quadrature 3 Map NO Quadrature 4 Map NO Quadrature 1 Raw YES Quadrature 2 Raw NO Quadrature 3 Raw NO Quadrature 4 Raw NO Enter=Select Ctrl+Arrow=Move Font Color Backcolor Justify Width F03 Esc=Abort F10=Save</p> <p>Figure 41</p>
---	--

Use [shortcuts](#) to change text attributes: Font select, text Color, \updownarrow text position, text Background, field Width and text Justification. "When to display" allows user to select when text is displayed. Options are: At power up or when function key F1..F7 is pressed.

Figure below shows quadrature count based on the line resolution selection X1, X2, X4:

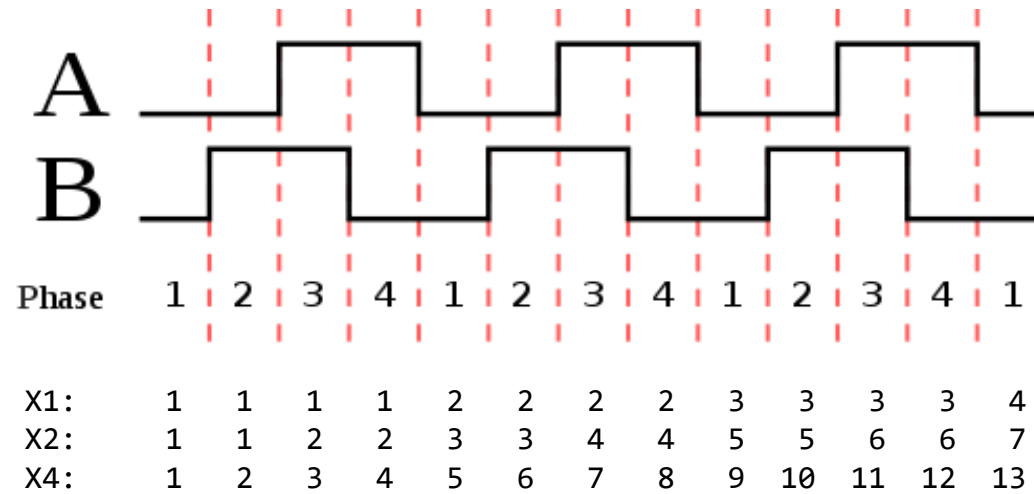

Quadrature counts are also available in Map format. The relation between the Raw count and Map parameter is shown below:

$$Map = m * Raw + b$$

$m = slope$
 $b = intercept$

EXAMPLE 1

Configure Quadrature 1 for 1.234 feet/count and display result.

Follow Figure 37:Figure 39 to set Quadrature 1 "Slope" and "Intercept" to 1.234 and 0 respectively.

Follow Figure 37 & Figure 40:Figure 41 to display "Quadrature 1 Map"

EXAMPLE 2

Configure Quadrature 4 for 0.0023 inch/count and display result.

Follow Figure 37:42 and set Quadrature 4 "Slope" and "Intercept" to 0.0023 and 0 respectively.

Follow Figure 37 & Figure 40:Figure 41 to display "Quadrature 4 Map"

INSERT AIRCRAFT SITUATION AWARENESS

As shown in Figure 42, Aircraft situation awareness widget depicts parameters such as heading, bearing (relative or magnetic), roll, pitch, azimuth, elevation and lens over a custom background image. The default background image shown in Figure 43 can be replaced by storing a new image ID#9. Font size & style can be change by replacing Font ID#18.

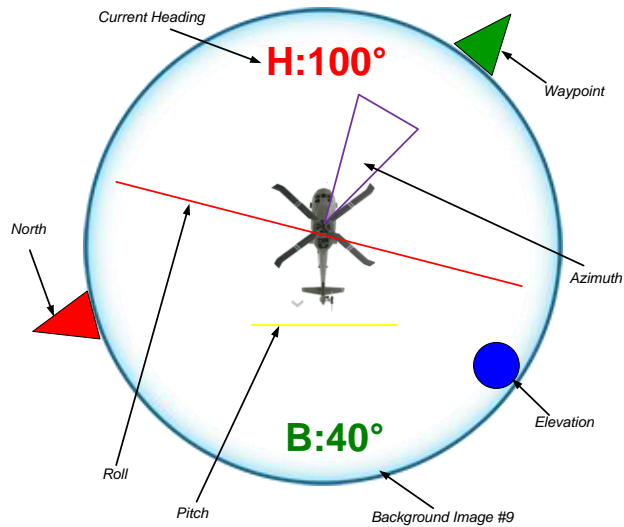

Figure 42

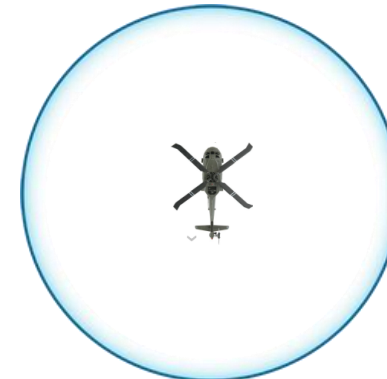

Figure 43

Follow Figure 44:Figure 45 to configure the widget.



Figure 44

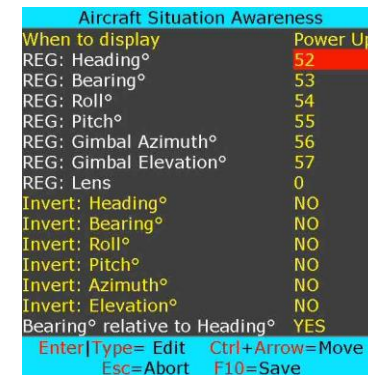

Figure 45

Follow Figure 45 to specify which register is associated with a specific parameter. For example, table below shows available options for heading:

Register # associated with Heading	Description
102	Heading is provided by attaching Garmin GPS modem to a COM port
110	Heading is provided by attaching Vector NAV INS sensor to a COM port
52	Heading is provided by transmitting a CSV sentence A to a COM port. Heading would be 1 st variable.
00	Do not display heading

The device (GPS, INS ...) specific registers are updated automatically when the device is connected to Proteus. Widgets that are associated to registers are automatically updated when the content of the registers change.

The content of any register can also be changed by sending Set Register Command. Assuming register 52 is linked to heading, command below will set the heading to 85°. Therefore, all widgets linked to register 52 will be updated automatically.

\$VL43, 52, 85*XX

Figure 46 demonstrates the relation between heading, relative vs magnetic bearing:

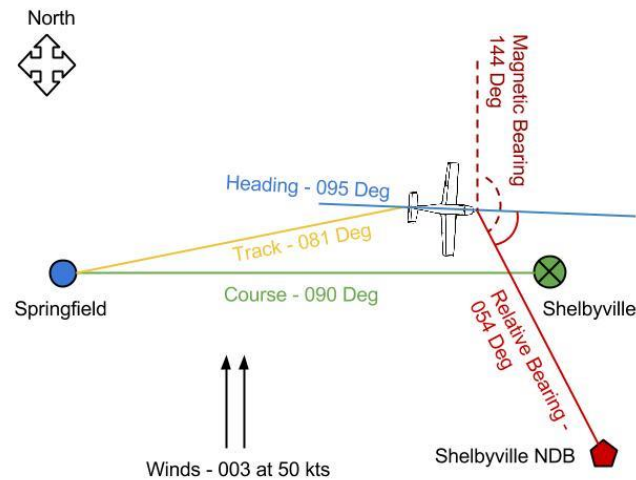

Figure 46

INSERT ROV SITUATION AWARENESS

As shown in Figure 47, Rov situation awareness widget depicts parameters such as heading, bearing (relative or magnetic), range to target, roll, pitch over a custom background image. The default background image shown in Figure 48 can be replaced by storing a new image ID#10. Font size & style can be change by replacing Font ID#18.

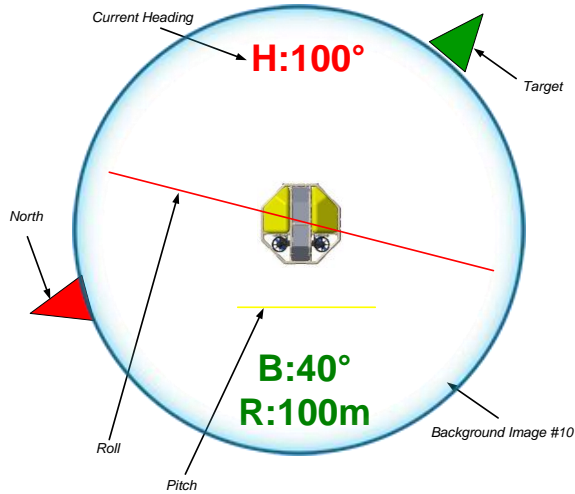

Figure 47

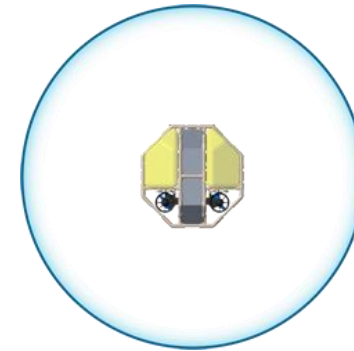

Figure 48

Follow Figure 49:Figure 50 to configure the widget.

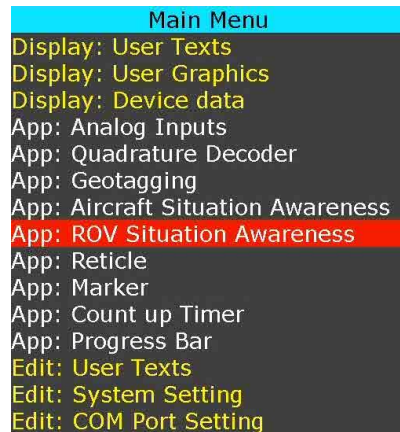

Figure 49



Figure 50

Follow Figure 50 to specify which register is associated with a specific parameter. For example, table below shows available options for heading:

Register # associated with Heading	Description
102	Heading is provided by attaching Garmin GPS modem to a COM port
110	Heading is provided by attaching Vector NAV INS sensor to a COM port
52	Heading is provided by transmitting a CSV sentence A to a COM port. Heading would be 1 st variable.
00	Do not display heading

The device (GPS, INS ...) specific registers are updated automatically when the device is connected to Proteus. Widgets that are associated to registers are automatically updated when the content of the registers change.

The content of any register can also be changed by sending Set Register Command. Assuming register 52 is linked to heading, command below will set the heading to 85°. Therefore, all widgets linked to register 52 will be updated automatically.

```
$VL43, 52, 85*XX
```

INSERT RETICLE

Up to 4 Reticles can be displayed at the same time. Follow Figure 51:Figure 53 to configure each Reticle:



Figure 51



Figure 52

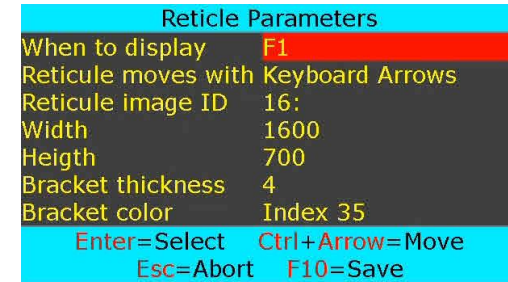

Figure 53

There are 3 options for controlling reticle movement:

Keyboard Arrow: Use $\updownarrow\leftrightarrow$ to move 1 pixel resolution. Use $Ctrl + \updownarrow\leftrightarrow$ to move 25 pixels

Analog Inputs: Apply 0..5 volts to control to CH1 & CH2 to control X & Y respectively

Quadrature Input: Attach Incremental Encoder switch to quadrature inputs# 1,2 to individually control X, Y respectively

RS232 Command: Send command $\$VL43,82,x,y*XX$ to set registers #82,83 to control X, Y movement respectively

Follow Figure 53 to configure the reticle size (width, height) and bracket thickness and color.

Follow Figure 54:Figure 55 to display Reticle X, Y coordinates.

Alternatively, launch *ProteusApp USB*, select *Demo/Tutorial* tab and write configuration file *C:\VideoLogix-IV\Config\ConfigReticle* to restore screen as shown in Figure 56.



Figure 54



Figure 55

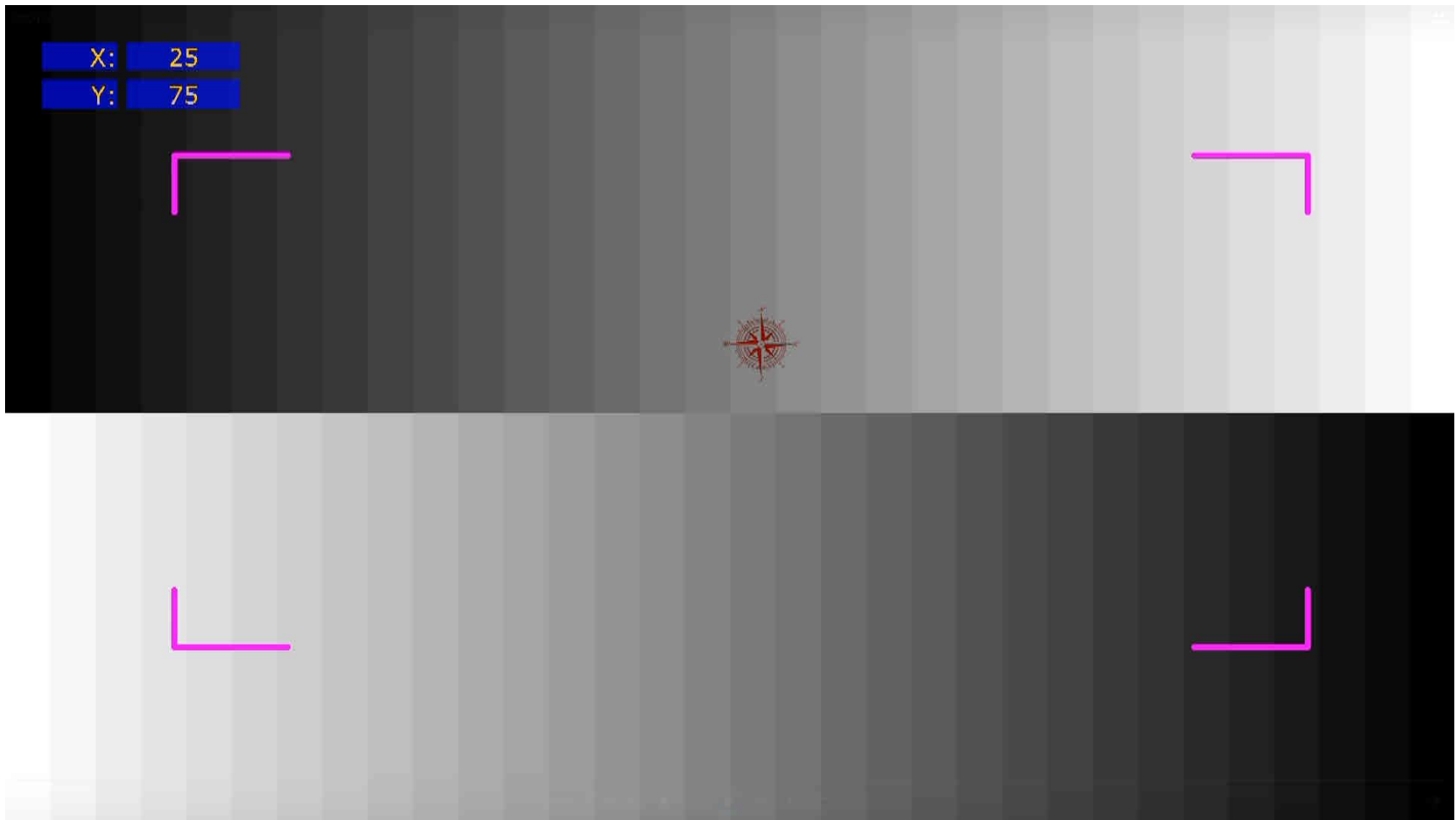

Figure 56

INSERT VIDEO MARKER

Follow Figure 57:Figure 59 to configure Marker:



Figure 57



Figure 58



Figure 59

There are 4 options for X1, X2, Y1, Y2 marker movement:

- Keyboard Arrow:** Use \updownarrow to move 1-pixel resolution. Use $\text{Ctrl} + \updownarrow$ to move 25 pixels
- Analog Inputs:** Apply 0..5 volts (i.e. analog joystick, potentiometer) to CH1-CH4 to individually control X1,X2,Y1,Y2 respectively
- Quadrature Inputs:** Incremental encoder switches (shown below) are connected to quadrature inputs# 1,2,3,4 to control X1, X2, Y1, Y2 respectively
- RS232 Command:** Send command $\$VL43,90,x1,x2,y1,y2*XX$ to set registers #90,91,92,93



Use Figure 59 to configure the Marker size (width, height), frame (thickness, color) and slope & intercept applied to DX, DY. Formula below defines the relationship between marker positions and calibrated measurements (CX, CY)

$$\begin{aligned}
 DX &= |X2 - X1| & DX &= \text{Delta } X \\
 DY &= |Y2 - Y1| & DY &= \text{Delta } Y \\
 CX &= mx * DX + bx & CX &= \text{Calibrated } DX \\
 CY &= my * DY + by & CY &= \text{Calibrated } DY
 \end{aligned}$$

Follow Figure 57, Figure 60:Figure 61 to display Marker parameters.

Alternatively, launch *ProteusApp USB*, select *Demo/Tutorial* tab and write configuration file *C:\VideoLogix-IV\Config\ConfigMarker* to restore screen as shown in Figure 62.



Figure 60

Marker Parameters	
When to display	Power Up
X1	YES
X2	YES
Y1	YES
Y2	YES
DX (Delta X)	YES
DY (Delta Y)	YES
CX (Calibrated DX)	YES
CY (Calibrated DY)	YES
Enter=Select Ctrl+Arrow=Move	
Font Color Backcolor Justify Width	
F03 Esc=Abort F10=Save	

Figure 61

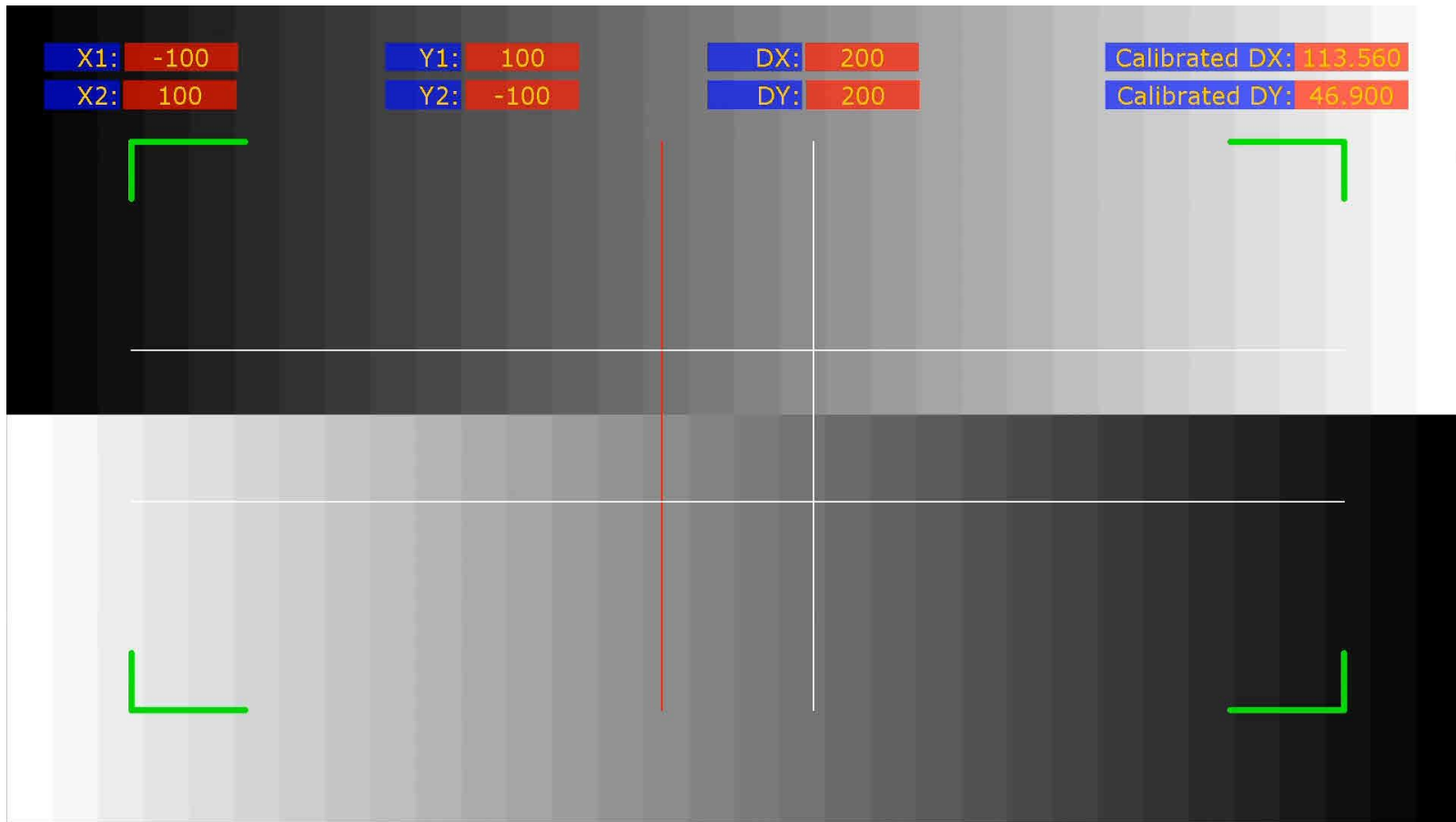

Figure 62

INSERT COUNT UP TIMER

Proteus provides highly accurate Count Up timer. Follow Figure 63:Figure 64 to configure the timer.



Figure 63



Figure 64

TIMER FORMAT

- HH:MM:SS.FF where FF is frame number
- HH:MM:SS
- MM:SS

SOURCE OF 1-PPS SIGNAL

Source	Description
CVBS: PPS	Apply 1-PPS signal to Composite Input
CVBS: IRIG	Apply IRIG-B006 signal to Composite Input
IN8: PPS	Apply 1-PPS signal to digital input IN8
RTC: PPS	Use 1-PPS signal from internal real time clock

EXTERNAL RESET

Count Up timer can be reset by grounding **IN7**. Reset occurs within 10 nsec.

WHEN

Count Up timer features (enable, display, pause/resume) can be assigned to function keys F1..F7 keys or digital inputs IN1..IN4

INSERT PROGRESS BARS & SLIDERS

Proteus provides Simple & Graphic progress bar. Follow Figure 65:Figure 68 to configure the progress bar.

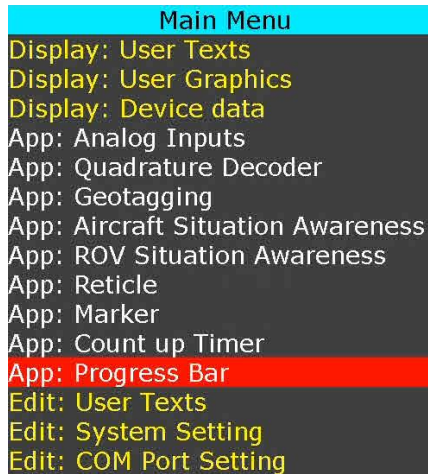

Figure 65



Figure 66



Figure 67

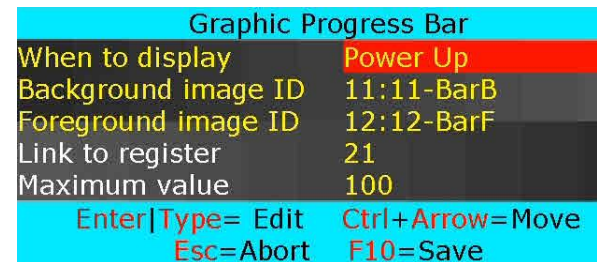

Figure 68

Progress bars must be linked to a register. Registers are updated via associated sensors or through RS232 commands. When the linked register receives a new value, progress bar is updated automatically.

Assuming progress bar is linked to register #52, RS232 command \$VL43, 52, 30*XX will set progress bar to 30%.

Assuming progress bar is linked to analog registers i.e. #14, when analog input #1 voltage changes, the progress bar is automatically updated.

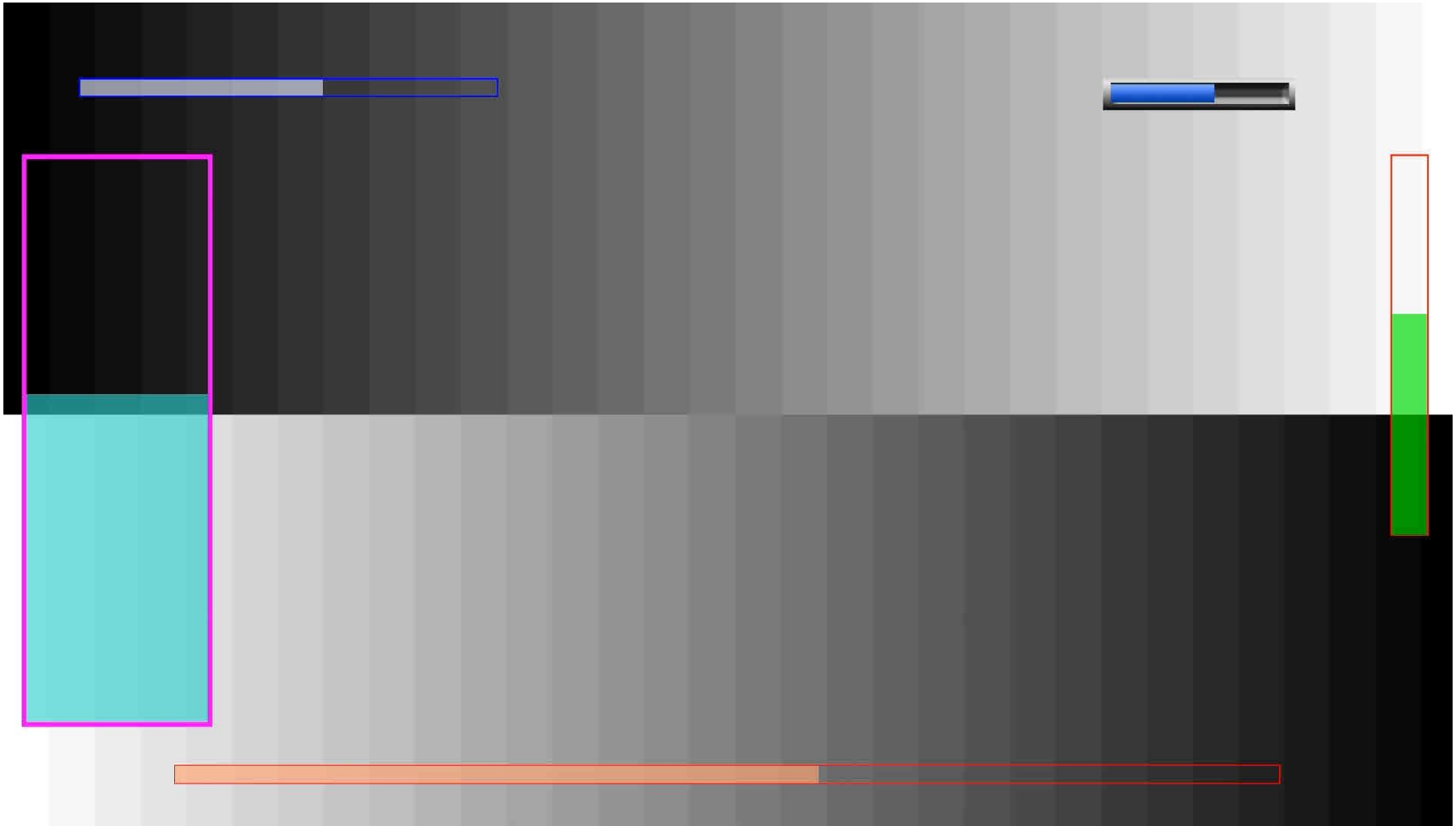

Figure 69

WRITE GEOTAG DATA

Geotagging is the process of adding geographical data (metadata) such as latitude & longitude coordinates, time, altitude, bearing etc. in each video frame. Proteus does not store metadata into a separate media i.e. MMC. Instead, using a propriety method, each video frame is permanently stamped with the metadata.

Follow Figure 70 to set up Proteus for writing Geotag data to video.



Figure 70

READ GEOTAG DATA

There is no post processing required. Simply playback the video and Proteus will extract the metadata and provide a real-time feed to Google Earth. This feature allows the user to watch a recorded video and simultaneously view the exact location video was taken in Google Earth.

Follow Figure 71 to set up Proteus for reading Geotag data from video.

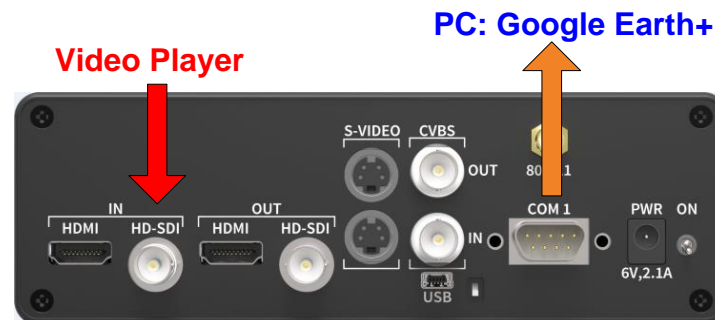

Figure 71

To use Proteus-IV with Google Earth use the steps below:

1. Visit <http://www.google.com/earth/index.html> and follow the onscreen prompts to install Google Earth
2. Once installed Click Tools
3. Click GPS
4. Click the Realtime tab (Figure 72)
5. Select NMEA protocol
6. Set 'Track point import limit' to 100
7. Set 'pulling interval' to 1 sec
8. Place a check mark next to 'Automatically follow the path'.
9. Click Start
10. Google Earth will begin to scan the different COM ports until it finds the port connected to Proteus (this may take a couple minutes)
11. Once Proteus is found, the map will automatically zoom into your current position on matching the video

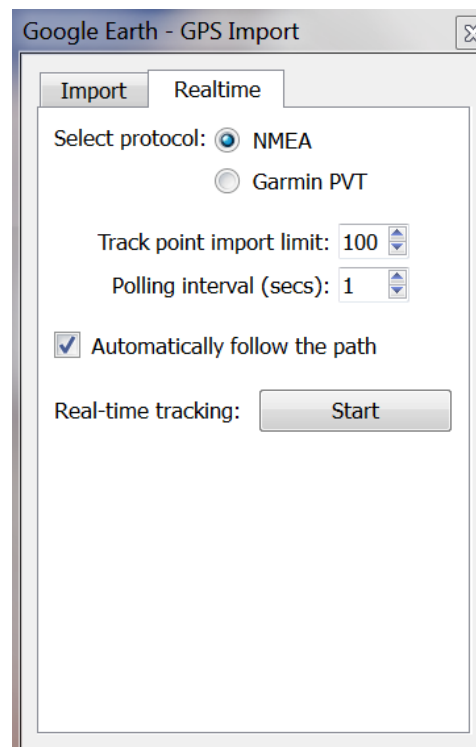

Figure 72

Follow Figure 73:Figure 74 to configure the geotagging.

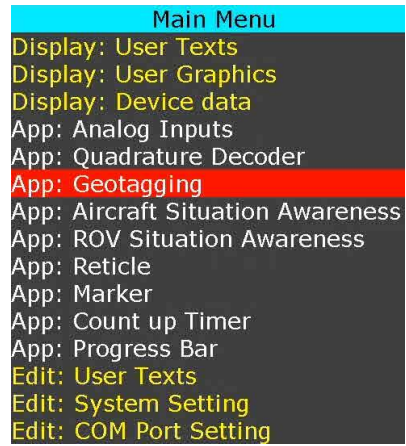

Figure 73

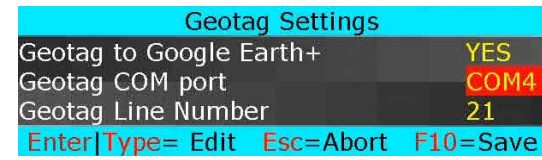

Figure 74

PROTEUS COMMANDS

Aside from supporting various connected devices, Proteus provides over 30 powerful commands to overlay crisp and clear texts, graphics and telemetry generated information into an incoming HD & SD video in real time. Refer to the Software Communication Spec (SCS) for the detail description of each command.

TRANSMIT A COMMAND SCRIPT

1. Connect Proteus to your monitor. Connect USB cable from your PC to the Proteus. Power on Proteus.
2. Run *ProteusApp USB 921K Baud* located in folder *C:\VideoLogix-IV*.
3. Ensure that RS232 LED toggles every time you click "Clear Layer 0" button.
4. Go to "Demo/Tutorial" tab.
5. Click *Write Configuration* button and load *C:\VideoLogix-IV\Config\ConfigScreen*.
6. Click *Run Script Now* button and load *C:\VideoLogix-IV\Script\0-TestCommands*.
7. A demo should appear on your video monitor.

PROTEUS REGISTERS

Proteus system contains a collection of registers used for configuring the system and accessing the data it produces. These registers may be read or written to using the Read Register and Write Register commands (refer to SCS for detail). The table below provides a quick reference for all of the registers and their associated properties. The device specific (Cineflex, IMU, GPS ...) registers are automatically updated when the associated device is connected to Proteus. Widgets that are linked to a register are updated automatically when the content of the register changes.

Register ID	Contents	Description
3	Video Mode SD	
4	Video Mode HD	
5	UTC Offset	-HH:MM
6	Proteus RTC Time	Time & Date from Proteus built-in clock
7	Proteus RTC Date	
8	IRIG-B RTC Time	External IRIB-B source
9	IRIG-B RTC Date	
10	Video Ancillary Time Code	
11	Video Ancillary Date Code	
12	Count Down Timer	HH:MM:SS, MM:SS, SS, HH:MM:SS:FF
13	Count Up Timer	HH:MM:SS, MM:SS, SS, HH:MM:SS:FF
14	Analog Input 1 : Raw ₁	
15	Analog Input 2 : Raw ₂	
16	Analog Input 3 : Raw ₃	
17	Analog Input 4 : Raw ₄	
18	Analog Input 5 : Raw ₅	
19	Analog Input 6 : Raw ₆	
20	Analog Input 7 : Raw ₇	
21	Analog Input 8 : Raw ₈	
22	Analog Input 1 : Map ₁	
23	Analog Input 2 : Map ₂	
24	Analog Input 3 : Map ₃	

25	Analog Input 4 : Map ₄		
26	Analog Input 5 : Map ₅		
27	Analog Input 6 : Map ₆		
28	Analog Input 7 : Map ₇		
29	Analog Input 8 : Map ₈		
30	Analog Input 1: Raw Differential ₁		
31	Analog Input 2: Raw Differential ₂		
32	Analog Input 3: Raw Differential ₃		
33	Analog Input 4: Raw Differential ₄		
34	Analog Input 1: Map Differential ₁		
35	Analog Input 2: Map Differential ₂		
36	Analog Input 3: Map Differential ₃		
37	Analog Input 4: Map Differential ₄		
38	Quadrature 1: Raw ₁		
39	Quadrature 2: Raw ₂		
40	Quadrature 3: Raw ₃		
41	Quadrature 4: Raw ₄		
42	Quadrature 1: Map ₁		
43	Quadrature 2: Map ₂		
44	Quadrature 3: Map ₃		
45	Quadrature 4: Map ₄		
46	INPUT1..8		State of digital inputs
47	Counter-1		
48	Counter-2		
49	Counter-3		
50	Counter-4		
51	Token-HeaderA		
52	TokenA1		
53	TokenA2		

54	TokenA3	<i>Parameters read from a CSV sentence A</i>	
55	TokenA4		
56	TokenA5		
57	TokenA6		
58	TokenA7		
59	TokenA8		
60	TokenA9		
61	TokenA10		
62	TokenA11		
63	TokenA12		
64	Token-HeaderB		<i>Parameters read from a CSV sentence B</i>
65	TokenB1		
66	TokenB2		
67	TokenB3		
68	TokenB4		
69	TokenB5		
70	TokenB6		
71	TokenB7		
72	TokenB8		
73	Token-HeaderC	<i>Parameters read from a CSV sentence C</i>	
74	TokenC1		
75	TokenC2		
76	TokenC3		
77	TokenC4		
78	TokenC5		
79	TokenC6		
80	TokenC7		
81	TokenC8		
82	Reticle1 X		
83	Reticle1 Y		

84	<i>Reticle2 X</i>	
85	<i>Reticle2 Y</i>	
86	<i>Reticle3 X</i>	
87	<i>Reticle3 Y</i>	
88	<i>Reticle4 X</i>	
89	<i>Reticle4 Y</i>	
90	<i>Marker X1</i>	<i>Data associate with XY measurements</i>
91	<i>Marker X2</i>	
92	<i>Marker Y1</i>	
93	<i>Marker Y2</i>	
94	<i>Marker Δx</i>	
95	<i>Marker Δy</i>	
96	<i>Marker Mapped_Δx</i>	
97	<i>Marker Mapped_Δy</i>	
98	<i>BMP: Pressure</i>	
99	<i>BMP: Temperature</i>	
100	<i>BMP: Altitude</i>	
101	GPS COM1,4: Altitude	<i>Parameters read from GPS Modem#1 connected to port COM1 or COM4</i>
102	GPS COM1,4: Coarse(heading) Over Ground	
103	GPS COM1,4: Speed Over Ground	
104	GPS COM1,4: Time	
105	GPS COM1,4: Date	
106	GPS COM1,4: Latitude (±dd.dddd)	
107	GPS COM1,4: Longitude(±ddd.dddd)	
108	GPS COM1,4: Latitude (dd° mm' ss.s")	
109	GPS COM1,4: Longitude (dd° mm' ss.s")	
110	GPS COM2,3: Altitude	
111	GPS COM2,3: Coarse(heading) Over Ground	
112	GPS COM2,3: Speed Over Ground	
113	GPS COM2,3: Time	

114	GPS COM2,3: Date	<i>Parameters read from GPS Modem#2 connected to port COM2 or COM3</i>
115	GPS COM2,3: Latitude ($\pm dd.ddddd$)	
116	GPS COM2,3: Longitude($\pm ddd.ddddd$)	
117	GPS COM2,3: Latitude ($dd^\circ mm' ss.s''$)	
118	GPS COM2,3: Longitude ($dd^\circ mm' ss.s''$)	
119	INS: Heading	
120	INS: Pitch	
121	INS: Roll	
122	INS: Altitude	
123	INS: Latitude ($\pm dd.ddddd$)	
124	INS: Longitude ($\pm ddd.ddddd$)	
125	INS: Time	
126	INS: Date	
127	INS: Latitude ($dd^\circ mm' ss.s''$)	
128	INS: Longitude ($dd^\circ mm' ss.s''$)	
129	\$SDDBT : Depth (m)	
130	\$SDDPT: Water Depth relative to transducer(m)	
131	\$SDDPT: Offset from transducer (m)	
132	\$SDDPT: Maximum range scale in use	
133	\$WIMTW: Water Temperature in C	
134		
135		
136		
137		
138		
139		
140		
141		
142		
143		

144		
145		
146		
147		
148		
149		
150		
151		
152		
153		
154		
155		
156		
157		
158		
159		
160		
161		
162		
163	APOS: Xpos	<i>APOS for HIPAP System</i>
164	APOS: Ypos	
165	APOS: Zpos	
166	APOS: FXpos	
167	APOS: FYpos	
168	APOS: FZpos	
169	MRA: Altitude	<i>Parameters read from SMARTMICRO Micro Radar Altimeter</i>
170	MRA: Vertical Speed	
171	Cineflex: Azimuth	
172	Cineflex: Elevation	
173	Cineflex: Roll	

174	Cineflex: Focus	<i>Parameters read from GENERAL DYNAMICS Cineflex gyro-stabilized Camera Systems</i>
175	Cineflex: Zoom	
176	Cineflex: Iris	
177	Cineflex: Tele	
178	Cineflex: Pan	

SPECIFICATIONS

MAXIMUM INPUT VOLTAGE

Min (DCIN)	Max (DCIN)	Power
6VDC	42VDC	6 watts

INPUT CONNECTOR

DC power jack is standard 2 conductors, center pin positive, 2.1mm ID, 5.5mm OD. Digikey P# CP-002A.

MAXIMUM TEMPERATURE

Specifications (DCIN = 6V)	Min	Max
Operating Temperature	10° C	40° C
Storage Temperature	-40° C	115° C

WEIGHT & DIMENSION

Weight	1.61 lb.
Dimension	6.310 x 6.300 x 2.25 (in)

FRONT PANEL LED

Proteus provides five LED in the front panel. COM LED for Communication and GPS LED as General-Purpose Status. Table below describes the behaviors of each LED.

LED	Description
Power	<i>ON when power is applied</i>
Status	<i>Blinks at 1Hz when system is working properly</i>
Video	<i>ON when an external video input is present</i>
RS232	<i>Toggles when an RS232 message is received</i>
WiFi	<i>Toggles when a WiFi message is received</i>

PCB DIMENSION

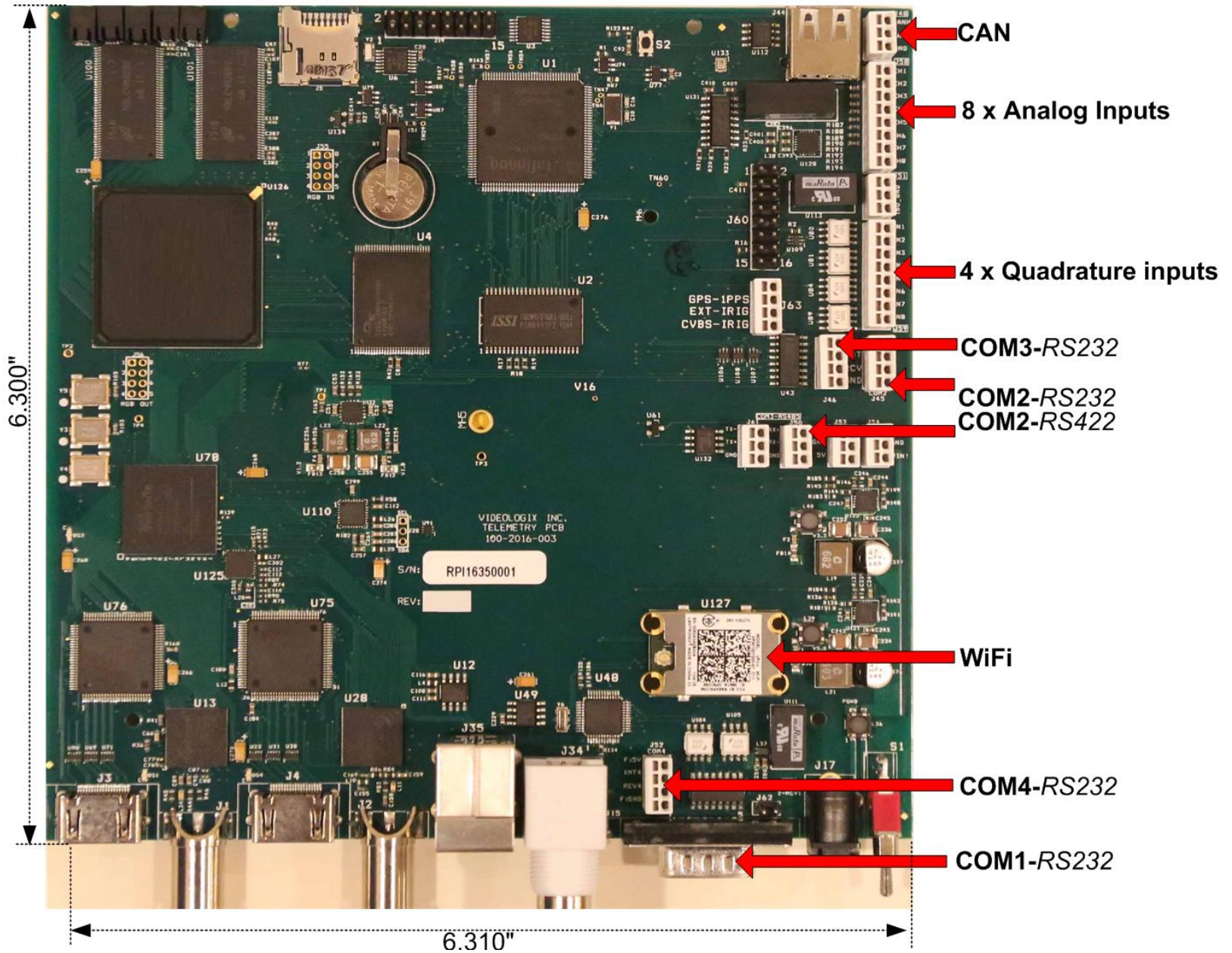

APPENDIX A - KEYBOARD

PS2 KEYBOARD COMMANDS

Keyboard command	Description
F1...F7	Execute Macro # 1...4
F8	Shortcut to "Edit: User Texts"
F9	Launch Main Menu
F10	Save changes & exit Main Menu
ESC	Abort changes and exit Main Menu
Alt + G	Draw 50 x 50-pixel gridlines on video
Alt + H	Help
ALT + CTRL + SHIFT + R	Erase all Macros & Strings from FLASH

KEYBOARD SHORT CUT

Keyboard command	Description
C or Ctrl + C	Change text Color
F or Ctrl + F	Change font type
B or Ctrl + B	Change text background
W or Ctrl + W	Change width of the field
J or Ctrl + J	Select Left, Center to Right justification
Ctrl + Arrow or Alt + Arrow	Move text location

APPENDIX B – DOWNLOAD CUSTOM FONTS

DOWNLOAD USER FONTS

FONT0 through FONT15 can be customized by the user. To create and download FONTS, perform the following steps:

1. Connect a Video Monitor to Proteus HD-SDI or HDMI output. Power on the Monitor.
2. Connect Proteus to a PC using USB cable. Power on Proteus.
3. Launch **ProteusApp**. Verify communication is working by clicking "**Clear Layer 0**" button.
4. Go to "Font + Bitmask" tab.
5. In order to download Font ID#3, within the "Font Selection" box, click on Row #3
6. Click "**Select Font**" button and select your desired font type, style, etc.
7. Click "**Create Font File**" button.
8. Select your desired ISO Character set template i.e. C:\videologix-IV\Fonts\ISO Font Template*ISO8859-9 Latin1.txt*
9. Type a file name for your font and press save.
10. Press "**Download Font File**" button. Select the font file name you created in step 9.
11. Font #3 will be stored on to FLASH. Upon completion, Monitor should display "Font Store Successful 3"

ISO 8859 is a full series of 10 (and soon even more) standardized multilingual single-byte coded (8bit) graphic character sets for writing in alphabetic languages:

- *Latin1 (West European)*
- *Latin2 (East European)*
- *Latin3 (South European)*
- *Latin4 (North European)*
- *Cyrillic*
- *Arabic*
- *Greek*
- *Hebrew*
- *Latin5 (Turkish)*
- *Latin6 (Nordic)*

APPENDIX C – INSTALL MEMTOOL

INSTALL MEMTOOL

1. Use Windows Explorer and browse to folder “C:\VideoLogix-IV\memtool”
2. Right click on “Infineon-Memtool-DT-v04_73-EN” application
3. Select “Run as administrator”
4. Follow Figure 75-Figure 80



Figure 75

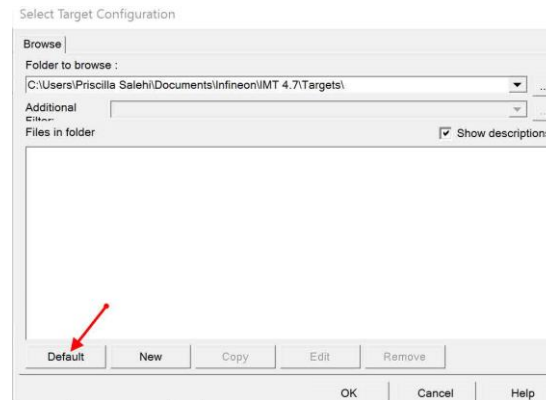

Figure 76

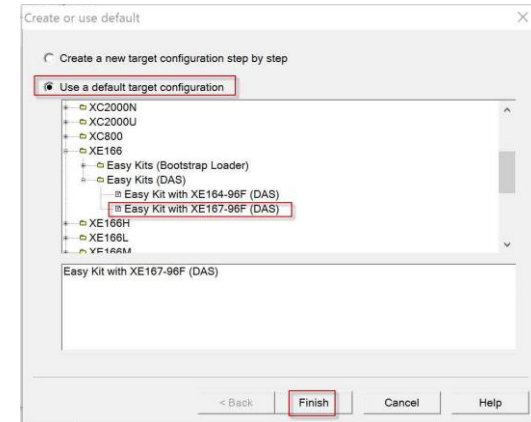

Figure 77

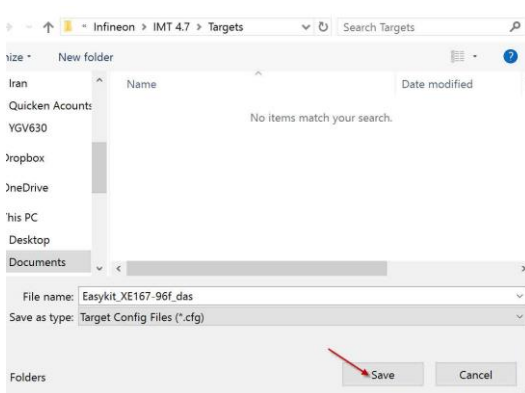

Figure 78

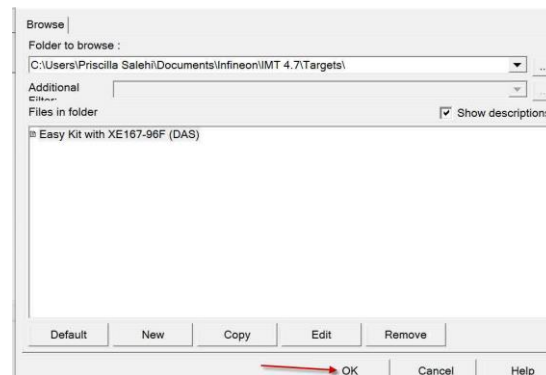

Figure 79

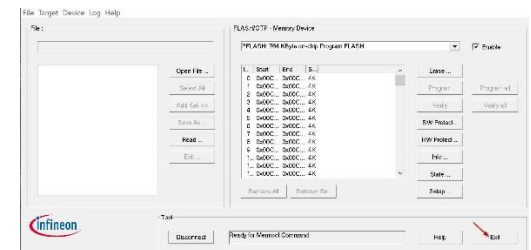

Figure 80

5. You are done.

CONFIGURE MEMTOOL

1. Connect Proteus to your PC using a standard USB cable.
2. Power on Proteus.
3. Windows should recognize Proteus and generate a sound.
4. Open Window's Device Manager and ensure highlighted items in Figure 81 have been identified by the Windows.

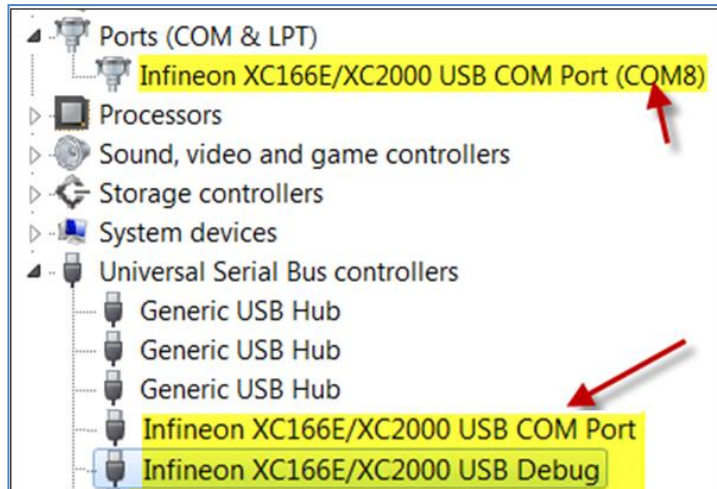

Figure 81

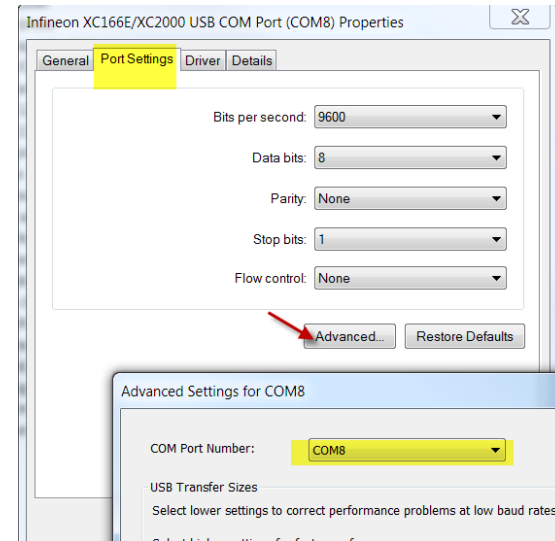

Figure 82

5. Ensure COM# is between COM1..COM8 is assigned.
6. If COM# is greater than 8, double click on i.e. COM8 line and go to tab "Port Setting", double click on "Advanced..." button and modify COM# as shown below to something between COM1..COM8.
6. Run **ProteusApp-USB**. Go to "File", "[Select Com Port...](#)" and ensure the corresponding COM# is selected.
7. Click "Clear Layer 0". **ProteusApp** should not display a Transmit Error message.
8. Monitor the RS232 LED on Proteus. Every time you click "Clear Layer 0", it should toggle.
9. Exit **ProteusApp-USB**. You are done.

APPENDIX D – DOWNLOAD CPU FIRMWARE

This section *assumes* you have already installed memtool application software. If you haven't done so, install memtool per instructions described in [Appendix C](#).

FIRMWARE UPGRADE

1. Press "*Connect*" button [0] in Figure 83. Confirmed "*Ready for Memtool Command*" is displayed in Figure 84.
2. Click "*Open File ...*" button [1] in Figure 85 and browse to the location `C:\Videologix-IV\Firmware\VxPx.H86` to obtain latest firmware. You may have to change the file extension to "H86-Files" as shown below:



3. Click "*Select All*" button [2] in Figure 85
4. Click "*Add Sel >>*" button [3] in Figure 85
5. Click "*Program*" button [4] in Figure 85. Memtool will start programming Proteus
6. Verify memtool displays "*success*" in Figure 86
7. Click "Exit" button in Figure 86
8. Click "Disconnect" button in Figure 85
9. Exit memtool
10. Cycle power to Proteus
11. Verify Front Panel Status LED is flashing

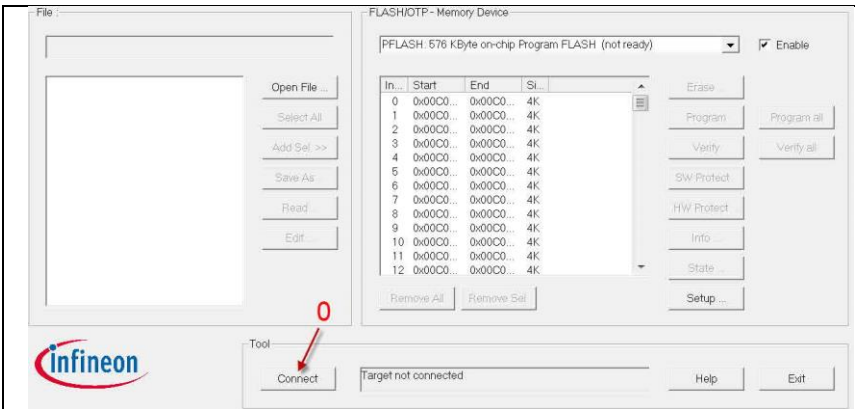

Figure 83

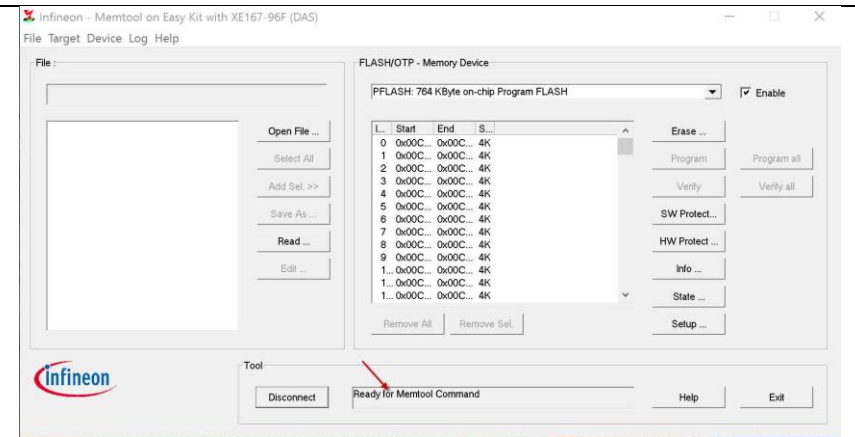

Figure 84

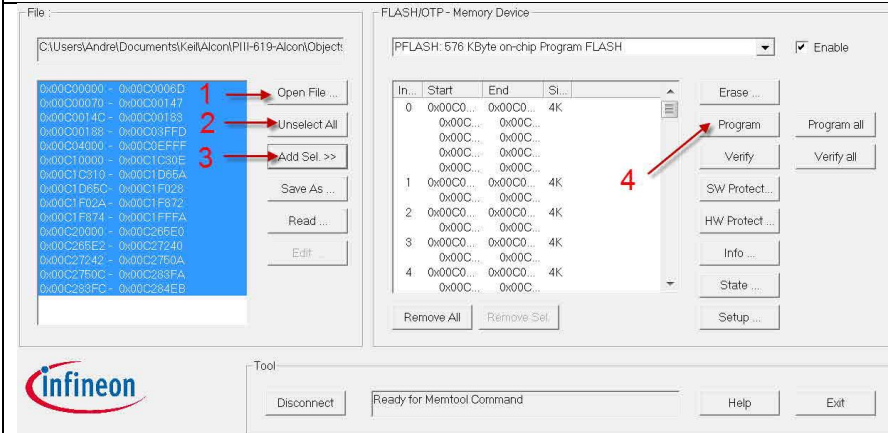

Figure 85

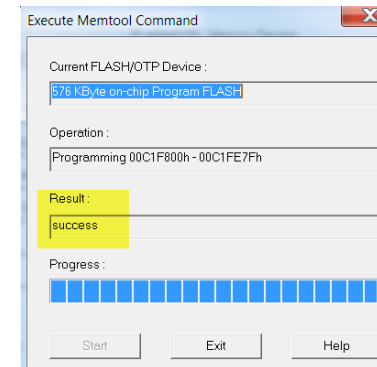

Figure 86

APPENDIX F – DOWNLOAD FPGA FIRMWARE

This section *assumes* you have already installed memtool application software. If you haven't done so, install memtool per instructions described in [Appendix C](#).

FPGA UPGRADE

1. Power up Proteus. Connect Proteus to your PC via standard USB cable
2. Start **ProteusApp-USB 921K** and select “Font + Bitmask” tab [1] in Figure 87
3. Verify COM LED toggles every time you click “Clear Layer 0” button. If not ensure COM3 baud is set to 921,600.
4. Click button [2] in Figure 87 and browse to *C:\Videologix-IV\Firmware\FPGA-SDI*.BIN* to obtain the FPGA firmware.
5. After about 30 seconds, as shown in Figure 88, a ‘*Success!*’ message should be displayed.
6. Press OK and exit **ProteusApp**. Cycle power to Proteus.
7. You are done.

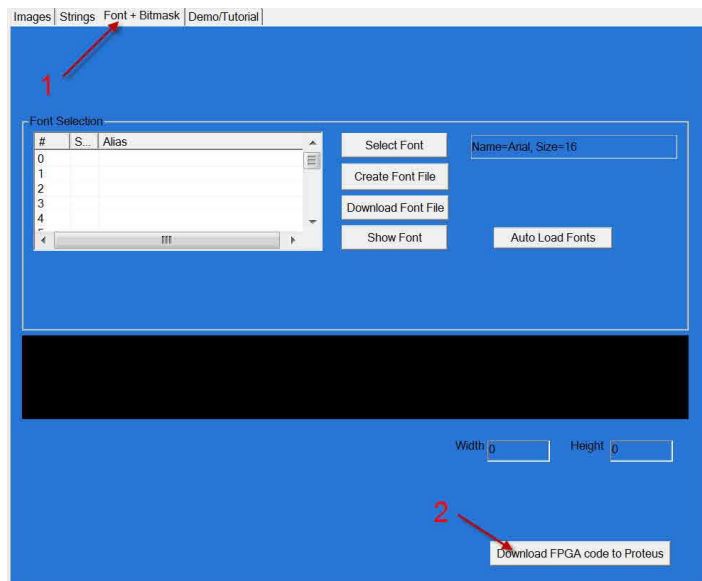

Figure 87

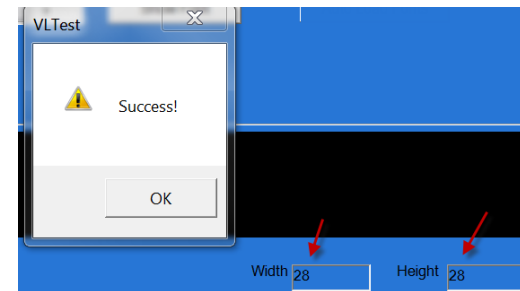

Figure 88

APPENDIX G – ANALOG INPUT SENSOR CALIBRATION

EXAMPLE 1

Configure analog channel 1 to convert ±10V input to display ±6 knots:

Input					ADC Count	Represent (knots)
5V	10V	±2.5V	±5V	±10V		
-	-	-	-	-10	0	-6
-	-	-	-	0	2047	
-	-	-	-	+10	4095	+6

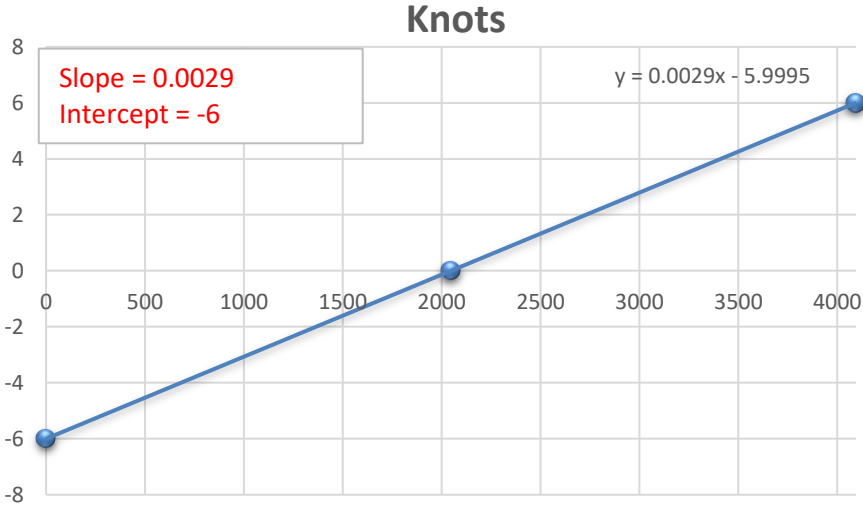

Follow Figure 32:37 and set CH1 "Signal Range" to "0±10V" and "Slope" & "Intercept" to 0.0029 and -6 respectively.
 Follow Figure 32 & Figure 35:39 to display "Analog Input #1 Map"

EXAMPLE 2

Configure analog channel 8 to convert 0-5V input to display 0 - 667.5 feet.

Input					ADC Count	Represent (Knots)
5V	10V	±2.5V	±5V	±10V		
0	-	-	-	-	0	0
	-	-	-	-	2047	
5	-	-	-	-	4095	667.5

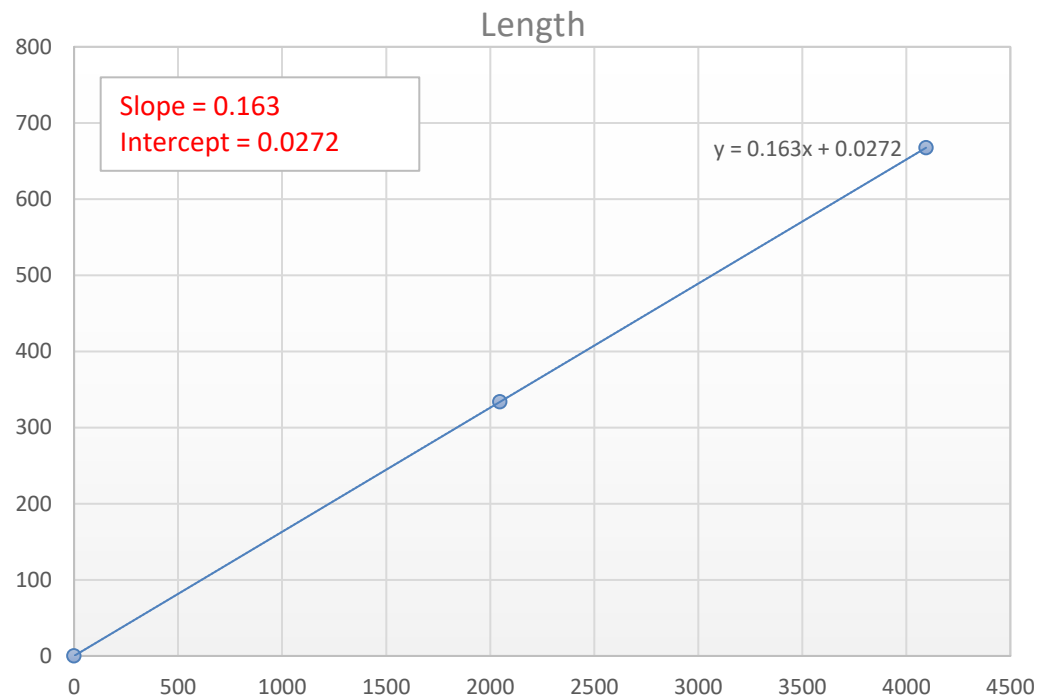

Follow Figure 32:37 and set CH8 "Signal Range" to "0-5V" and "Slope" & "Intercept" to 0.163 and 0.0272 respectively.

Follow Figure 32 & Figure 35:39 to display "Analog Input #8 Map"

EXAMPLE 3

Configure analog channel 4 to convert 0-10V input to display 0 - 65psi

Input					ADC Count	Represent (PSI)
5V	10V	±2.5V	±5V	±10V		
-	0	-	-	-	0	0
-		-	-	-	2047	
-	10	-	-	-	4095	65

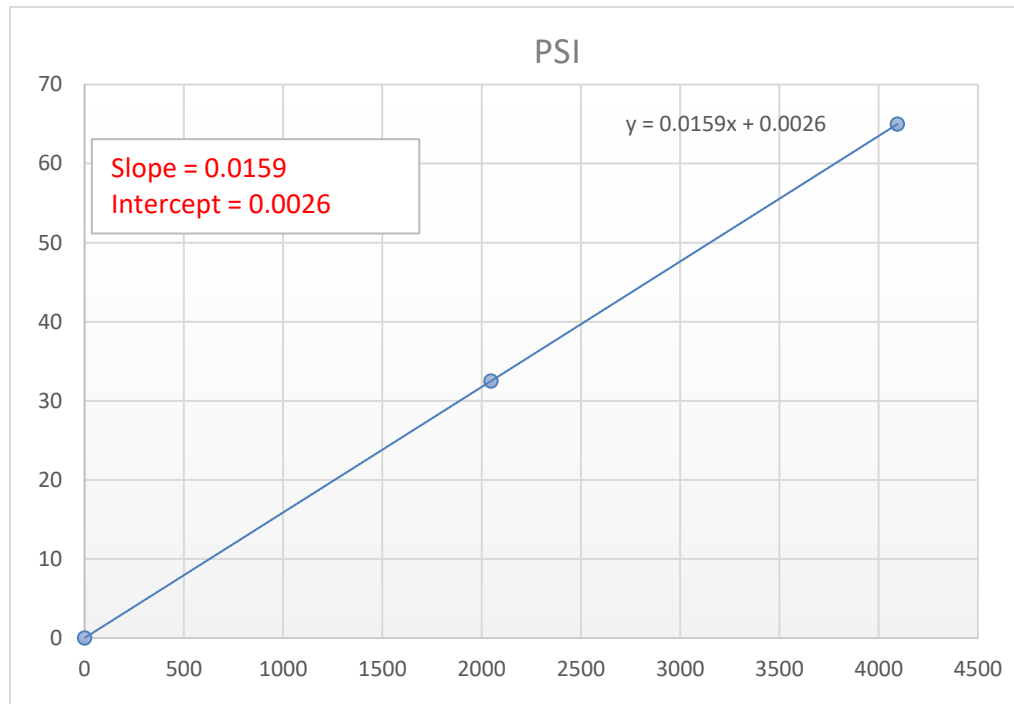

Follow Figure 32:37 and set CH4 "Signal Range" to "0-10V" and "Slope" & "Intercept" to 0.0159 and 0.0026 respectively.

Follow Figure 32 & Figure 35:39 to display "Analog Input #4 Map"

CURRENT LOOP 4-20mA

Sensors with a 4-20 mA current loop output are extremely common in industrial measurement and control applications. The 4-20mA control loops, are used to transmit various process signals representing flow, speed, position, level, temperature, pressure, strain, pH, etc.

The transmitter typically uses 4mA output to represent the calibrated zero input or 0%, and 20mA output to represent a calibrated full-scale input signal or 100% as shown in Figure 4 below:

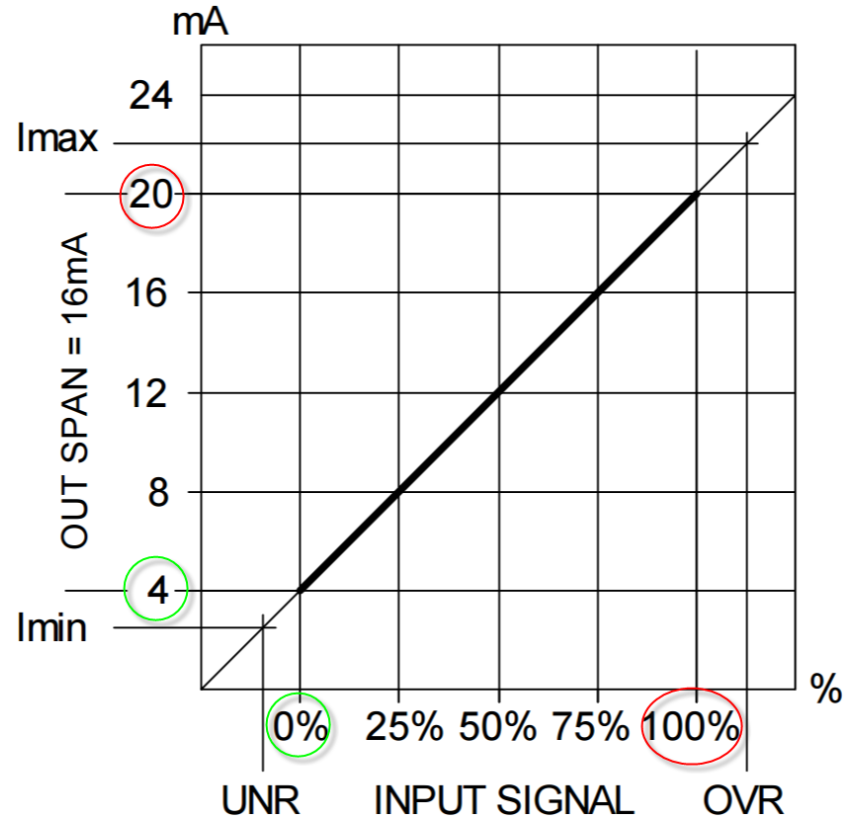

4-20ma current loop can be converted to a voltage with a precision load resistor. The voltage produced across a load resistor is easily scaled by simply changing the resistance. Common resistances used are 250 Ω (1-5V), 500 Ω (2-10V), 50 Ω (0.2-1V), and 100 Ω (0.4-2V).

EXAMPLE 4

Configure analog channel 3 to convert 4-20ma with 250Ω load resistor to 0-100°C.

Load Resistance	250Ω	
Current Loop, amp:	0.004 A	0.020 A
Generated voltage (across 250Ω):	1 V	5 V
Voltage represents:	0°C	100°C

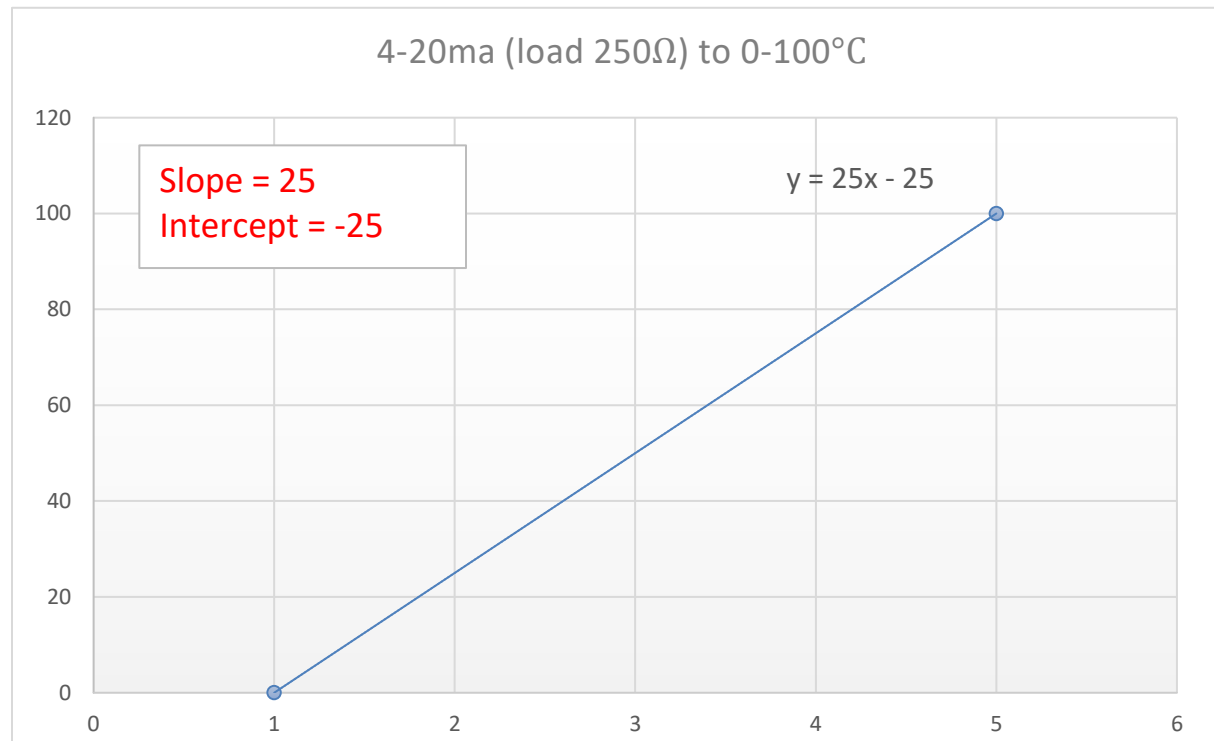

Follow Figure 32:37 and set CH3 “Signal Range” to “0-5V” and “Slope” and “Intercept” to 25 and -25 respectively.

Follow Figure 32 & Figure 35:39 to display “Analog Input #3 Map”

EXAMPLE 5

Configure an analog channel 7 to convert 4-20ma with 500Ω load resistor to 0-65 PSI.

Load Resistance	500Ω	
Current Loop, amp:	0.004 A	0.020 A
Generated voltage (across 500Ω):	2 V	10 V
Voltage represents:	0 PSI	65 PSI

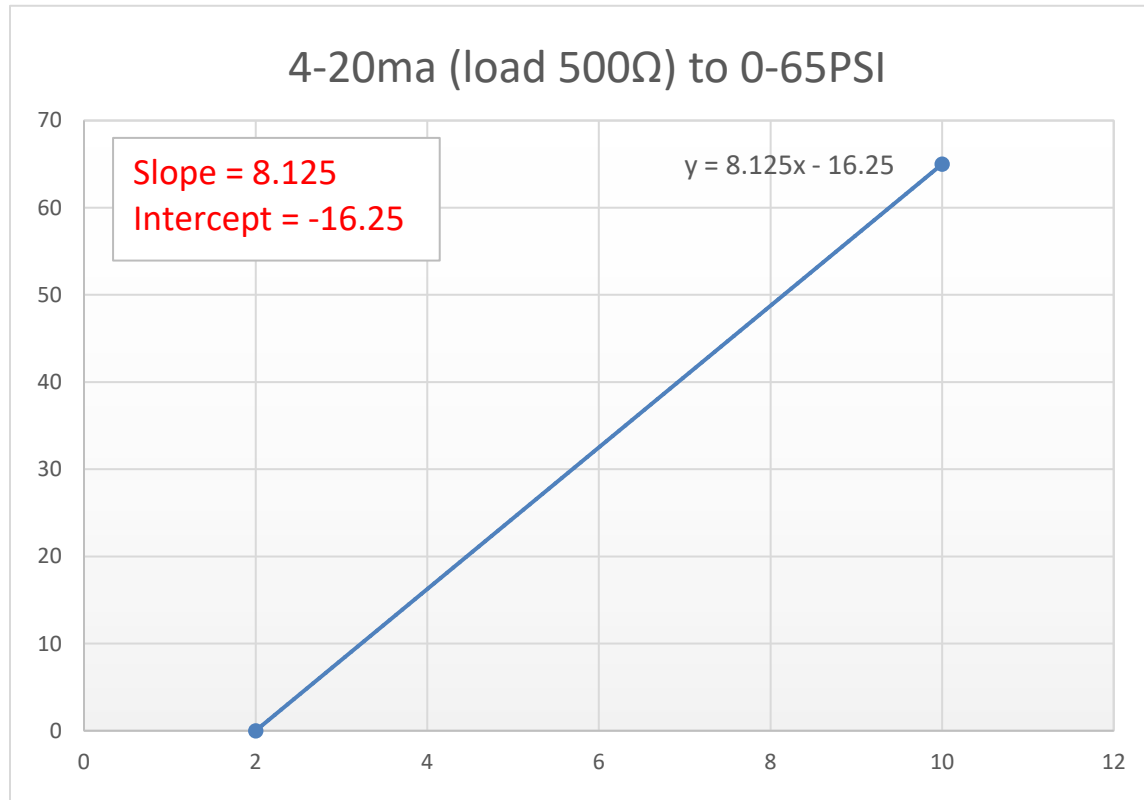

Follow Figure 32:37 and set CH7 "Signal Range" to "0-10V" and "Slope" and "Intercept" to 8.125 and -16.25 respectively.

Follow Figure 32 & Figure 35:39 to display "Analog Input #3 Map"

APPENDIX H – WIFI SETTING

WIFI

WiFi module is configured as a Soft Access Point (SoftAP) with the following default SSID and password:

SSID	eVideologix
Password	PROTEUS-IV
IP Address	192.168.0.1
Port	10001

Press F9 to display the Main Menu. Follow Figure 89:Figure 90 to enable WiFi.



Figure 89

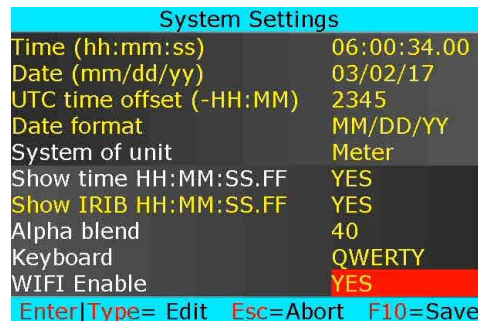

Figure 90

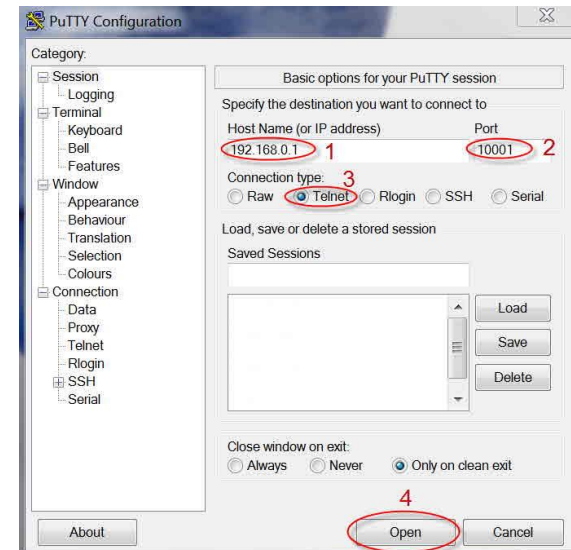

Figure 91

EXAMPLE

Terminal program such as PuTTY can be used to send commands via WiFi to Proteus:

1. Use SSID & Password shown above connect your PC to Proteus WiFi
2. Open PuTTY and configure as shown in Figure 91

Follow "Insert variables from csv sentence" and ignore instruction "Follow Figure 1: Figure 2 to configure COM port for desire baudrate.."

APPENDIX I – TERMINAL BLOCKS

HOW TO INSERT WIRE INTO TERMINAL BLOCKS

Care must be taken when inserting wire into terminal blocks. Do not insert thick screwdriver into terminal block as it will permanently damage the internal spring-loaded contacts. In general, any blade with 0.4mm x 2mm cross section is appropriate. Digikey P#1205202 is factory approved.

We have learned that X-ACTO Knife shown below works best.

